

# Z01B-SG™ TEAM

## SETUP SHEET

DRIVER: \_\_\_\_\_ EVENT: \_\_\_\_\_ DATE: \_\_\_\_\_ TRACK: \_\_\_\_\_

**TRACK CONDITIONS**  INDOOR  OUTDOOR  SMOOTH  ROUGH  LOOSE  HARD PACKED  
 DRY  WET  DUSTY  LOW BITE  MED BITE  HIGH BITE

### FRONT END

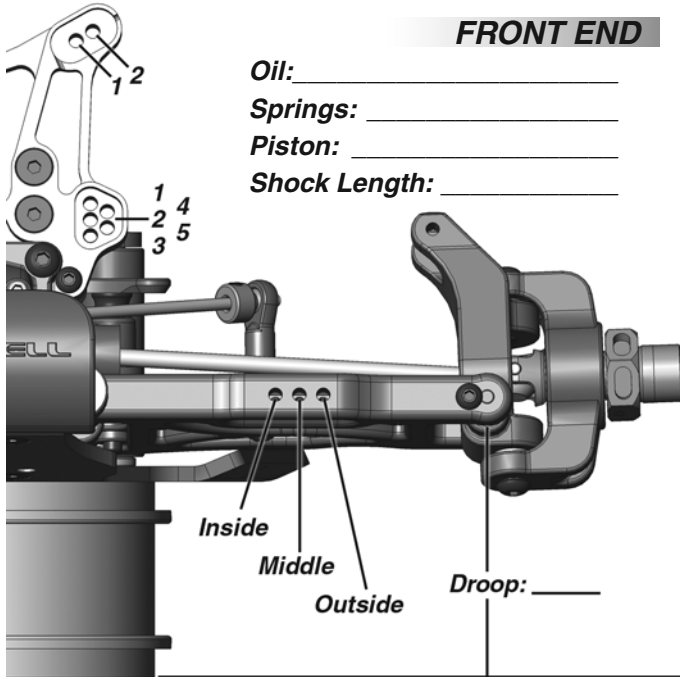

Oil: \_\_\_\_\_  
Springs: \_\_\_\_\_  
Piston: \_\_\_\_\_  
Shock Length: \_\_\_\_\_

Inside \_\_\_\_\_  
Middle \_\_\_\_\_  
Outside \_\_\_\_\_  
Droop: \_\_\_\_\_

Bumpsteer Spacers: \_\_\_\_\_  
Sway Bar: \_\_\_\_\_  
Lower Caster Block Bushings: \_\_\_\_\_  
Ride Height: \_\_\_\_\_  
Camber: \_\_\_\_\_ Toe: \_\_\_\_\_

### REAR END

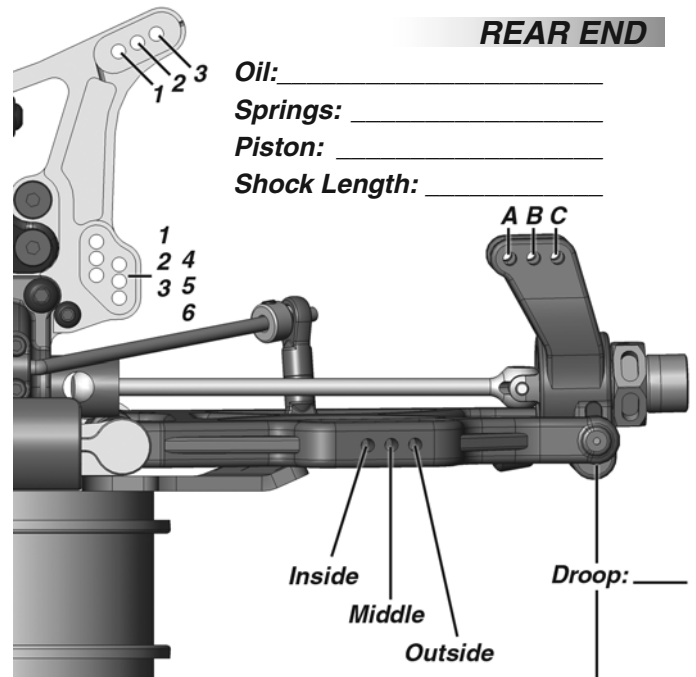

Oil: \_\_\_\_\_  
Springs: \_\_\_\_\_  
Piston: \_\_\_\_\_  
Shock Length: \_\_\_\_\_

A \_\_\_\_\_ B \_\_\_\_\_ C \_\_\_\_\_  
Inside \_\_\_\_\_  
Middle \_\_\_\_\_  
Outside \_\_\_\_\_  
Droop: \_\_\_\_\_

Hub Placement: \_\_\_\_\_  
Sway Bar: \_\_\_\_\_  
Anti-Squat: \_\_\_\_\_  
Wing Position: \_\_\_\_\_  
Ride Height: \_\_\_\_\_  
Camber: \_\_\_\_\_ Toe: \_\_\_\_\_

### DIFF OILS

Front: \_\_\_\_\_  
Center: \_\_\_\_\_  
Rear: \_\_\_\_\_  
Notes: \_\_\_\_\_  
\_\_\_\_\_

### ENGINE

Engine Type: \_\_\_\_\_  
Glow Plug: \_\_\_\_\_  
Head Clearance: \_\_\_\_\_  
Header: \_\_\_\_\_  
Pipe: \_\_\_\_\_  
Fuel: \_\_\_\_\_

### TIRES

Front Tire Type: \_\_\_\_\_  
Rear Tire Type: \_\_\_\_\_  
Front Compound: \_\_\_\_\_  
Rear Compound: \_\_\_\_\_  
Insert: \_\_\_\_\_  
Wheels: \_\_\_\_\_

### CLUTCH

# Shoes: \_\_\_\_\_  
Material: \_\_\_\_\_  
Springs: \_\_\_\_\_  
Notes: \_\_\_\_\_  
\_\_\_\_\_

### GEARING

Spur: \_\_\_\_\_  
Clutch Bell: \_\_\_\_\_  
Notes: \_\_\_\_\_  
\_\_\_\_\_  
\_\_\_\_\_

### COMMENTS

\_\_\_\_\_  
\_\_\_\_\_  
\_\_\_\_\_  
\_\_\_\_\_  
\_\_\_\_\_