

Driver: _____

Track: _____

Date: _____

Surface: _____

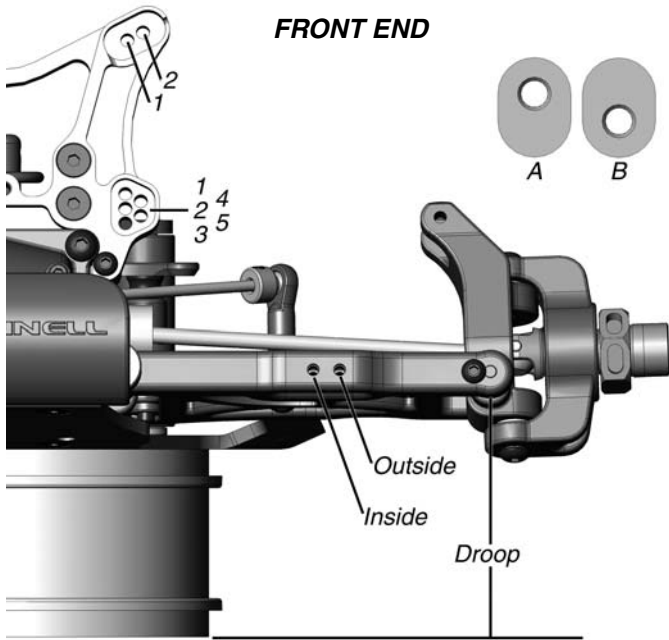

FRONT END

Oil: _____

Spring: _____

Piston: _____

Sway Bar: _____

Camber: _____

Toe: _____

Lower Caster Block Eccentric Bushing: _____

Inner Camber Link: _____

Upper Shock Placement: _____

Lower Shock Placement: _____

Droop: _____

Ride Height: _____

Bump Steer Spacers: _____

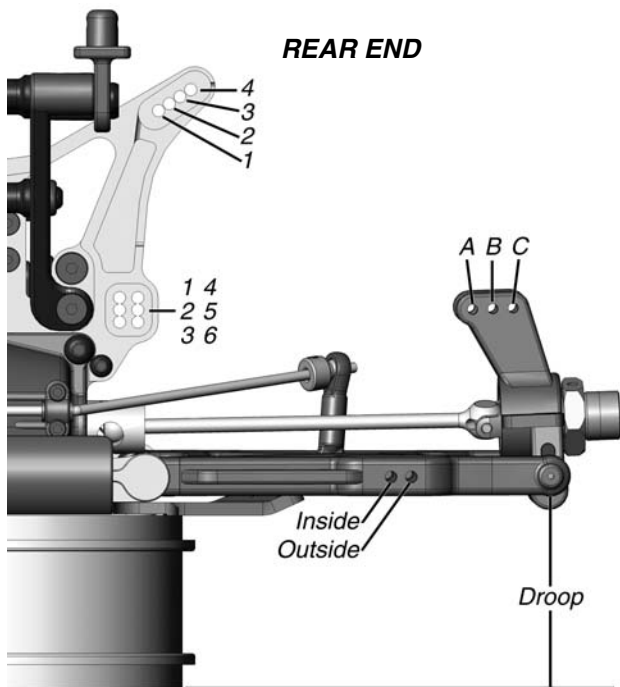

REAR END

Oil: _____

Spring: _____

Piston: _____

Sway Bar: _____

Camber: _____

Inner Camber Link: _____

Outer Camber Link: _____

Rear Toe-In: _____

Rear Anti-Squat: _____

Hub Carrier Placement: _____

Upper Shock Placement: _____

Lower Shock Placement: _____

Droop: _____

Ride Height: _____

Wing Position: _____

DIFF OILS:

CLUTCH

GEARING

SWAYBAR LEGEND

SPRING LEGEND

Front: _____

Shoes: _____

Spur: _____

A: .093

Blue (Softest)

Center: _____

Material: _____

Clutch Bell: _____

B: .100

Gray

Rear: _____

Springs: _____

C: .105

White

Silver (Hardest)

Note: Ride height is measured at the back of the chassis for the rear and at the bellcrank screws for the front.