

Driver: _____ Track: Basic Setup

Date: _____ Surface: _____

FRONT END

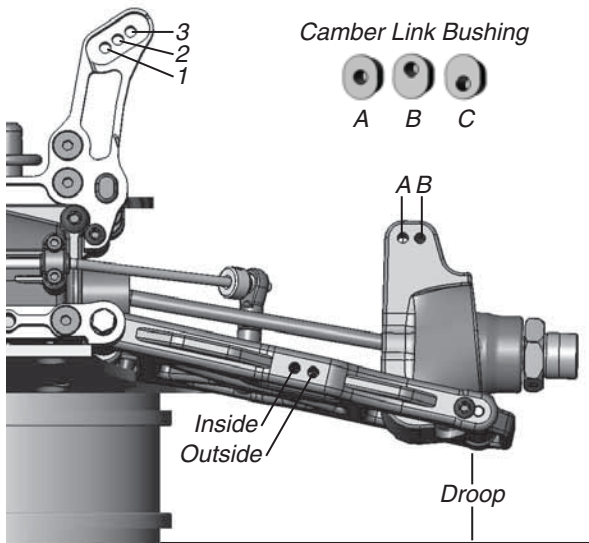

Oil: Hot Conditions: 40wt, Cold Conditions: 30wt

Spring: Black

Piston: Stock

Limiters: 0

Sway Bar: B

Camber: -2.5

Toe: -2.0

Camber Link Bushing: A, Center

Outer Camber Link: A

Caster Block: 10°

Ackerman Placement: Middle

Upper Shock Placement: 2

Lower Shock Placement: Inside

Droop: 34mm

Ride Height: 27mm

Bump Steer Spacers: 3 Washers on the Steering Knuckle

REAR END

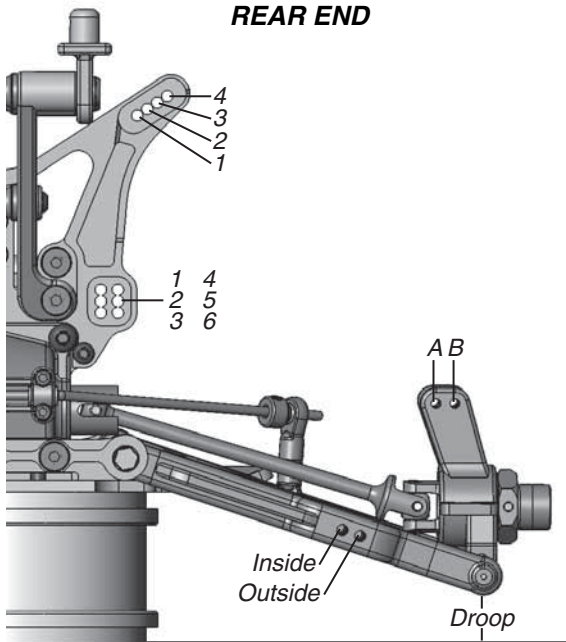

Oil: Hot Conditions: 30wt, Cold Conditions: 20wt

Spring: White

Piston: Stock

Limiters: 0

Sway Bar: B

Camber: -2.5

Inner Camber Link: 3

Outer Camber Link: A

Rear Toe-In: 2.5°

Rear Anti-Squat: 2°

Hub Carrier Placement: Down and Forward

Upper Shock Placement: 3

Lower Shock Placement: Inside

Droop: 17mm

Ride Height: 26mm

Wing Position: Upper

DIFF OILS:

Front: 5K

Center: 5K

Rear: 2K

CLUTCH

Shoes: Stock

Material: Stock

Springs: Stock

GEARING

Spur: 48T

Clutch Bell: 13T

SWAYBAR LEGEND

A: .093

B: .100

C: .105

SPRING LEGEND

Red (Softest)

Blue

Black

White (Hardest)

Note: Ride height is measured at the back of the chassis for the rear and at the bellcrank screws for the front.

Driver: _____ Track: _____

Date: _____ Surface: Loose Track

FRONT END

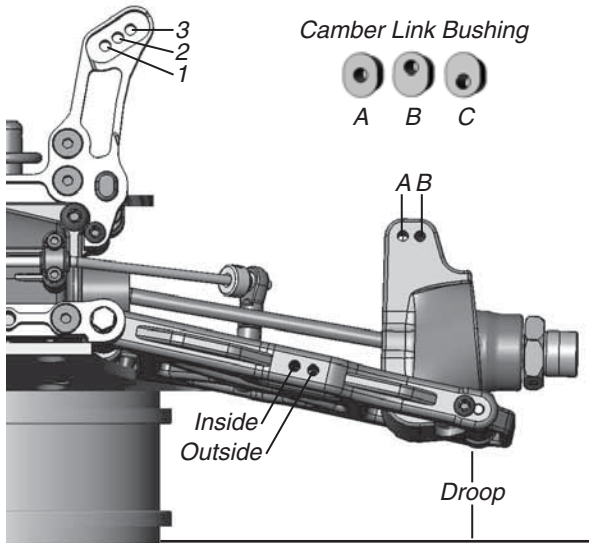

Oil: 35wt
 Spring: Blue
 Piston: Stock
 Limiters: 0
 Sway Bar: B
 Camber: -2.0
 Toe: -1.0
 Camber Link Bushing: C, Lower
 Outer Camber Link: B
 Caster Block: 10°
 Ackerman Placement: Middle
 Upper Shock Placement: 2
 Lower Shock Placement: Inside
 Droop: 38mm
 Ride Height: 27mm
 Bump Steer Spacers: 3 Washers on the Steering Knuckle

REAR END

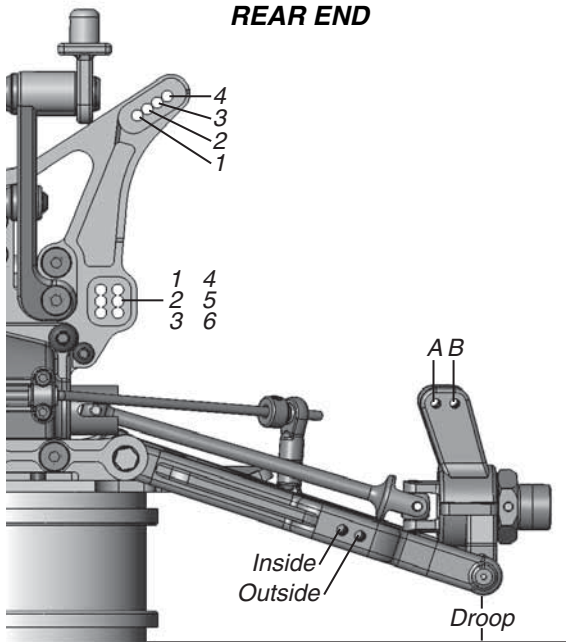

Oil: 30wt
 Spring: Black
 Piston: Stock
 Limiters: 0
 Sway Bar: B
 Camber: -2.0
 Inner Camber Link: 3
 Outer Camber Link: A
 Rear Toe-In: 3° (Optional)
 Rear Anti-Squat: 3° (Optional)
 Hub Carrier Placement: Down and Forward
 Upper Shock Placement: 3
 Lower Shock Placement: Inside
 Droop: 19mm
 Ride Height: 26mm
 Wing Position: Upper

DIFF OILS:	CLUTCH	GEARING	SWAYBAR LEGEND	SPRING LEGEND
Front: <u>7K</u>	Shoes: <u>Stock</u>	Spur: <u>48T</u>	A: <u>.093</u>	Red (Softest)
Center: <u>5K</u>	Material: <u>Stock</u>	Clutch Bell: <u>13T</u>	B: <u>.100</u>	Blue
Rear: <u>2K</u>	Springs: <u>Stock</u>		C: <u>.105</u>	Black
				White (Hardest)

Note: Ride height is measured at the back of the chassis for the rear and at the bellcrank screws for the front.

Driver: _____ Track: _____

Date: _____ Surface: Large Outdoor Track

FRONT END

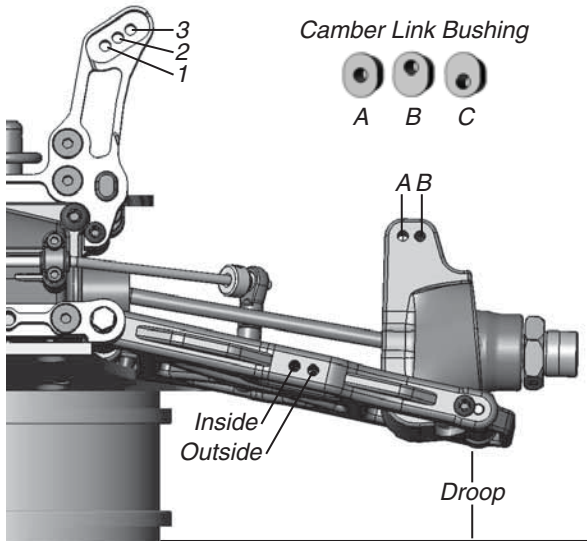

Oil: 35wt
 Spring: Black
 Piston: Stock
 Limiters: 0
 Sway Bar: C
 Camber: -2.5
 Toe: -1.0
 Camber Link Bushing: B, Upper
 Outer Camber Link: B
 Caster Block: 10°
 Ackerman Placement: Middle
 Upper Shock Placement: 2
 Lower Shock Placement: Inside
 Droop: 34mm
 Ride Height: 27mm
 Bump Steer Spacers: 3 Washers on the Steering Knuckle

REAR END

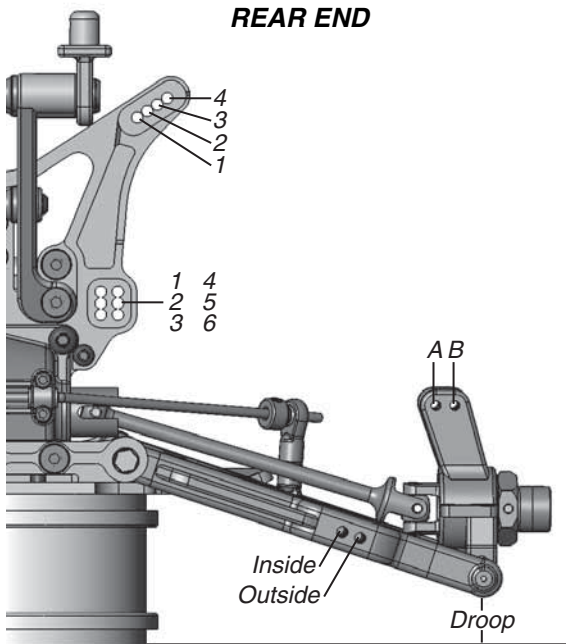

Oil: 30wt
 Spring: White
 Piston: Stock
 Limiters: 0
 Sway Bar: C
 Camber: -2.5
 Inner Camber Link: 2
 Outer Camber Link: A
 Rear Toe-In: -2.5°
 Rear Anti-Squat: 2°
 Hub Carrier Placement: Down and Middle
 Upper Shock Placement: 3
 Lower Shock Placement: Inside
 Droop: 12mm
 Ride Height: 26mm
 Wing Position: Upper

DIFF OILS:	CLUTCH	GEARING	SWAYBAR LEGEND	SPRING LEGEND
Front: <u>7K</u>	Shoes: <u>Stock</u>	Spur: <u>48T</u>	A: <u>.093</u>	Red (Softest)
Center: <u>5K</u>	Material: <u>Stock</u>	Clutch Bell: <u>13T</u>	B: <u>.100</u>	Blue
Rear: <u>3K</u>	Springs: <u>Stock</u>		C: <u>.105</u>	Black
				White (Hardest)

Note: Ride height is measured at the back of the chassis for the rear and at the bellcrank screws for the front.

Driver: _____ Track: _____

Date: _____ Surface: Rough Track

FRONT END

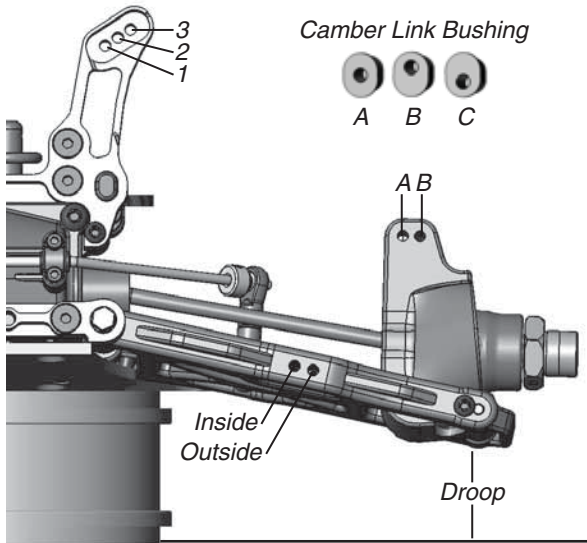

Oil: 30wt
 Spring: Red
 Piston: Stock
 Limiters: 0
 Sway Bar: B
 Camber: -2.5
 Toe: 0
 Camber Link Bushing: C, Lower
 Outer Camber Link: A
 Caster Block: 10°
 Ackerman Placement: Middle
 Upper Shock Placement: 2
 Lower Shock Placement: Inside
 Droop: 38mm
 Ride Height: 29mm
 Bump Steer Spacers: 3 Washers on the Steering Knuckle

REAR END

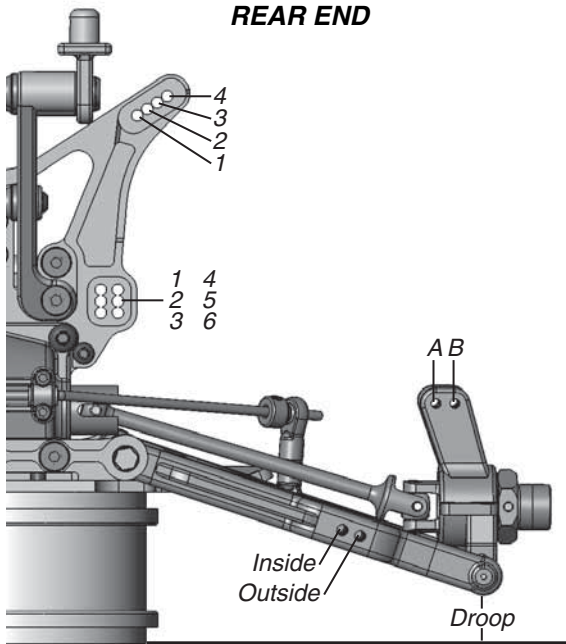

Oil: 25wt
 Spring: Blue
 Piston: Stock
 Limiters: 0
 Sway Bar: B
 Camber: -2.5
 Inner Camber Link: 6
 Outer Camber Link: A
 Rear Toe-In: 3° (Optional)
 Rear Anti-Squat: 3° (Optional)
 Hub Carrier Placement: Down and Middle
 Upper Shock Placement: 3
 Lower Shock Placement: Inside
 Droop: 12mm
 Ride Height: 28mm
 Wing Position: Upper

DIFF OILS:	CLUTCH	GEARING	SWAYBAR LEGEND	SPRING LEGEND
Front: <u>4K</u>	Shoes: <u>Stock</u>	Spur: <u>48T</u>	A: <u>.093</u>	Red (Softest)
Center: <u>4K</u>	Material: <u>Stock</u>	Clutch Bell: <u>13T</u>	B: <u>.100</u>	Blue
Rear: <u>2K</u>	Springs: <u>Stock</u>		C: <u>.105</u>	Black
				White (Hardest)

Note: Ride height is measured at the back of the chassis for the rear and at the bellcrank screws for the front.

Driver: _____ Track: _____

Date: _____ Surface: _____

FRONT END

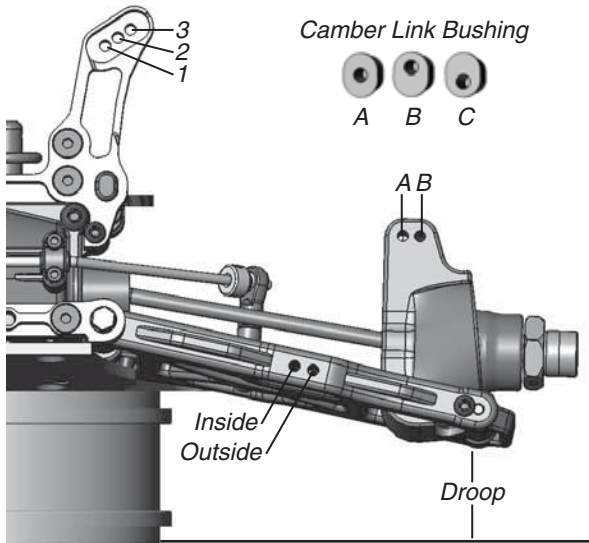

Oil: _____
 Spring: _____
 Piston: _____
 Limiters: _____
 Sway Bar: _____
 Camber: _____
 Toe: _____
 Camber Link Bushing: _____
 Outer Camber Link: _____
 Caster Block: _____
 Ackerman Placement: _____
 Upper Shock Placement: _____
 Lower Shock Placement: _____
 Droop: _____
 Ride Height: _____
 Bump Steer Spacers: _____

REAR END

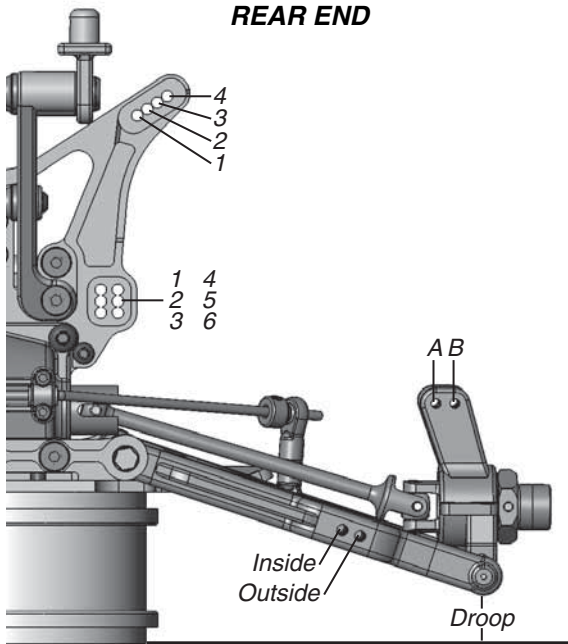

Oil: _____
 Spring: _____
 Piston: _____
 Limiters: _____
 Sway Bar: _____
 Camber: _____
 Inner Camber Link: _____
 Outer Camber Link: _____
 Rear Toe-In: _____
 Rear Anti-Squat: _____
 Hub Carrier Placement: _____
 Upper Shock Placement: _____
 Lower Shock Placement: _____
 Droop: _____
 Ride Height: _____
 Wing Position: _____

DIFF OILS:

Front: _____

Center: _____

Rear: _____

CLUTCH

Shoes: _____

Material: _____

Springs: _____

GEARING

Spur: _____

Clutch Bell: _____

SWAYBAR LEGEND

A: .093

B: .100

C: .105

SPRING LEGEND

Red (Softest)

Blue

Black

White (Hardest)

Note: Ride height is measured at the back of the chassis for the rear and at the bellcrank screws for the front.