

GREAT NEWS

GREAT PLANES MODEL DISTRIBUTORS

RADIO CONTROL • JUNE 2013

1SQ

V-CAM

Page 2-3



PLUS:

Helicopters
from Heli-Max®
Pages 4-7, 14-15

Hot Price on Team
Durango RTRs
Pages 30-31

America's
Best RC Sale
Pages 32-33

 **GREAT PLANES**
MODEL DISTRIBUTORS

GREAT NEWS

GREAT PLANES MODEL DISTRIBUTORS

GENERAL HOBBY • JUNE 2013



PLUS:

Latina New Arrivals
Pages 4-5

New Plastic Models
Pages 6-12

Lindberg Models
Pages 14-15

Pages 2-3

 **GREAT PLANES**
MODEL DISTRIBUTORS

YOU'LL FLIP OVER THIS CAMERA-EQUIPPED QUADCOPTER!

www.gpdealer.com

www.gpdealer.com



Not only do the LEDs add a cool look to the heli, they also help pilots with orientation, both day and night.

The camera measures only 1-1/2" x 3/4" x 1/3", and is compatible with memory cards up to 32G microSD size. It takes 1MP still photos in jpg format, as well as 1280x720 30fps videos in avi format.



Maximum stability from 3 gyros and 3 accelerometers

TAGS-FX continuously keeps you in complete control. Sensor Fusion Technology integrates data received from dual sources — a 3-axis gyro and a 3-axis accelerometer — and compensates immediately for any actions except those you command. TAGS-FX corrects unwanted movement in yaw, pitch and roll while also preventing drift in any direction. New pilots enjoy unprecedented confidence...experts gain the precision to execute perfect maneuvers. With TAGS-FX, you're more in control than ever before!

- Incredibly stable — ideal for indoor flying or outdoors in light winds
- Onboard micro video camera, controlled from the transmitter
- 2 gig micro SD memory card & USB micro SD card reader
- By pushing a button and moving the control stick the Auto-Flip function will flip the 1SQ V-Cam front-to-back, back-to-front or side-to-side
- 4 LED lights on motor pods

HMXE0836 1SQ V-Cam Quadcopter RTF
 HMXE0837 1SQ V-Cam Quadcopter Tx-R
 Length: 5.7 in (145 mm)
 Width: 5.7 in (145 mm)
 Blade Length: 2.16 in (55 mm)

From the Experts:

No other quadcopter offers everything the 1SQ V-Cam does! The TAGS-FX gyro system makes for rock-solid control when flying and hovering — great for new pilots — and the Auto-FLIP feature adds instant aerobatics. You can fly the 1SQ V-Cam at night with its motor pod-mounted LED lights.

Long story short...

The 1SQ V-Cam Quadcopter is the easy-to-fly fun machine that can also be your "eye in the sky"!





AXE™ 100SS

Brushless Flybarless Aerobatic Heli

STEP UP TO BRUSHLESS 3D AEROBATICS!



- Brushless motor with stand-alone ESC
- Flybarless, collective-pitch head
- TAGS three-axis gyro
- Beefed-up airframe
- Longer tail boom
- Independent rotary-drive servos
- Dependable, responsive motor-driven tail rotor
- Virtually unbreakable landing gear



The frame is an open design that's been molded to handle the demands of brushless power. Three independent digital servos feature rotary drive for exceptionally fast, precise response and full cases for added crash resistance.



The Axe 100 SS features a flybarless collective-pitch rotor head for superior agility and a factory-tuned TAGS three-axis gyro for rock-solid stability and tail control.



Total control — to the 3rd power!

TAGS does far more than any single-axis gyro. It simultaneously controls the yaw, pitch and roll axes of your heli, to provide stability no single-axis gyro can match. With TAGS, you can fly with confidence because it detects external forces and compensates to ensure that they won't affect performance. The result: smoother flight and a locked-in feel to the controls. It's standard equipment on all Axe helis — and once you've experienced TAGS, you won't ever want to fly without it!

Add strength, reliability, and good looks to your Axe100 with CNC-machined option parts!

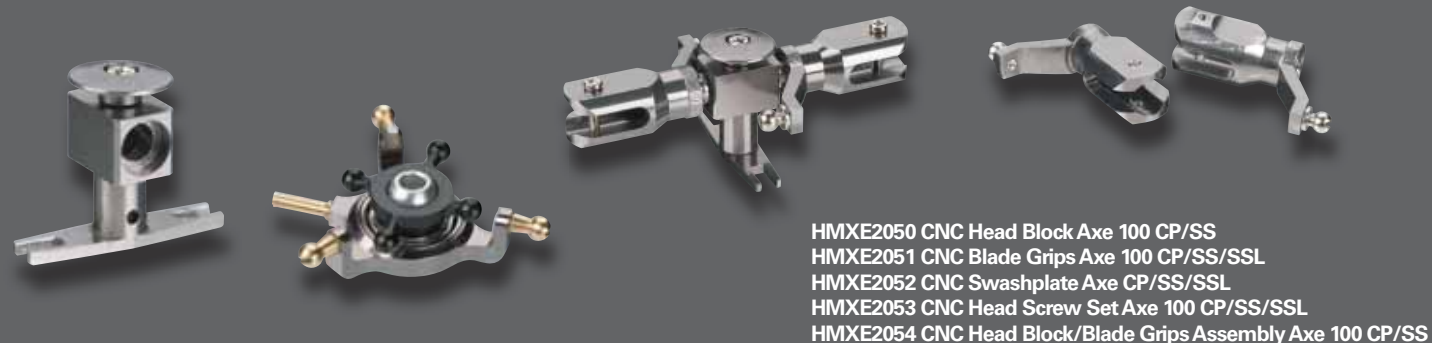

HMXE2050 CNC Head Block Axe 100 CP/SS
 HMXE2051 CNC Blade Grips Axe 100 CP/SS/SSL
 HMXE2052 CNC Swashplate Axe CP/SS/SSL
 HMXE2053 CNC Head Screw Set Axe 100 CP/SS/SSL
 HMXE2054 CNC Head Block/Blade Grips Assembly Axe 100 CP/SS



HMXE0824 Axe 100 SS Brushless Heli RTF
 HMXE0825 Axe 100 SS Brushless Heli Tx-R
 Rotor Diameter: 9.5 in (242 mm)
 Weight w/o battery: 1.7 oz (48 g)
 Length: 10.4 in (264 mm)

Heli-Max®

From the Experts:
 You can do more with the Axe 100 SS heli, because it offers more. The brushless motor delivers more power for executing 3D maneuvers, both indoors and out. The tail boom is extended for improved tail authority, and the airframe is stronger to accommodate the demands of brushless power. Plus, you have the flybarless, collective-pitch rotor head, the TAGS 3-axis gyro and your choice of the RTF's all-in-one-box convenience or the flexibility of the Tx-R!

Long story short...
 Expand your heli flying options — take the Axe 100 SS up for a spin!

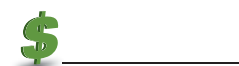

EXCITING HELI FLIGHTS — WITH LED LIGHTS!

AXE™ 100 SSL

Brushless Flybarless Aerobatic Heli w/LEDs



- Main blades feature blue LEDs on top and green on the bottom; the tail is identified by a single red LED
- Brushless motor with stand-alone ESC
- Flybarless, collective-pitch head
- TAGS Three-Axis Gyro
- Beefed-up airframe
- Longer tail boom
- Independent rotary-drive servos
- Dependable, responsive motor-driven tail rotor
- Virtually unbreakable landing gear



The frame is an open design that's been molded to handle the demands of brushless power. Three independent digital servos feature rotary drive for exceptionally fast, precise response and full cases for added crash resistance.



The Axe 100 SSL features a flybarless collective-pitch rotor head for superior agility and a factory-tuned TAGS three-axis gyro for rock-solid stability and tail control.



Total control — to the 3rd power!

TAGS does far more than any single-axis gyro. It simultaneously controls the yaw, pitch and roll axes of your heli, to provide stability no single-axis gyro can match. With TAGS, you can fly with confidence because it detects external forces and compensates to ensure that they won't affect performance. The result: smoother flight and a locked-in feel to the controls. It's standard equipment on all Axe helis — and once you've experienced TAGS, you won't ever want to fly without it!

From the Experts:

LEDs add another dimension to Axe 100 helis, and Heli-Max makes them easy to enjoy. Add the flybarless, collective-pitch rotor head, the TAGS 3-axis gyro and the option of convenient RTF or versatile Tx-R and you have an exciting new experience in heli flying!

Long story short...

Lift off with the Axe 100 SSL,
and fly by the light of LEDs!

Tx-R™
TRANSMITTER-READY

RTF
READY-TO-FLY

HMXE0827 Axe 100 SSL Brushless Heli w/LEDs RTF
HMXE0828 Axe 100 SSL Brushless Heli w/LEDs Tx-R
Rotor Diameter: 9.5 in (242 mm)
Weight w/o battery: 1.7 oz (48 g)
Length: 10.4 in (264 mm)

Heli-Max®

CHEVY CAMARO ZL1

Built for pure performance.

The 2012 model year marks the 45th anniversary of the Chevy® Camaro®, the iconic car that has ruled the streets of America with a combination of style and power. You'll find that same winning combination in this officially licensed R/C model of the Camaro® ZL1™. Underneath the sleek body is a lightweight aluminum chassis featuring high-performance goodies such as smooth-riding oil-filled shocks and pillow ball front suspension.



Ready-to-Run, 1/10 Scale Nitro 4WD



- High-rpm Duratrax 18R racing engine
- Super Start RTR hand-held starter system
- Bulletproof 2.4GHz radio with two powerful servos
- Four-wheel shaft drive for maximum traction
- Realistic, smooth-shifting 2-speed transmission
- Fully adjustable suspension for precise handling

DTXD53** Chevy® Camaro® ZL1™ 1/10 4WD Nitro 2.4GHz RTR
 DTXD53NN Chevy® Camaro® ZL1™ 1/10 4WD Nitro 2.4GHz RTR-Inferno Orange Metallic
 DTXD53RR Chevy® Camaro® ZL1™ 1/10 4WD Nitro 2.4GHz RTR-Victory Red
 Length: 17.1 in (435 mm)
 Width: 7.9 in (200 mm)
 Height: 4.7 in (120 mm)
 RTR Weight: 4.1 lb (1.84 kg)



Chevrolet, Camaro, all related Emblems and vehicle model body designs are General Motors Trademarks used under license to Hobbico Inc.



From the Experts:

Don't just hit the streets: OWN the streets, with Duratrax's Chevy® Camaro® ZL1™! With a nitro-burning engine and 2.4GHz radio already installed, you're just minutes from taking on the competition... and winning. The strong, lightweight aluminum chassis is topped off with a stylish ZL1 body, for looks to match its performance. And it's backed by the famous Stress-Tech Guarantee!

Long story short...

Whether you're a daredevil R/C driver or a Chevy® Camaro® buff – or both – you'll get into this replica of the Camaro® ZL1™!

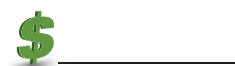

RACING RADIO FEATURES — PLUS TELEMETRY — AT A SPORT RADIO PRICE!

4-Channel 2.4GHz Computer Radio System w/Telemetry

4PLS



If knowledge is power, then the 4PLS is destined to be a driver's #1 advantage for getting to the winner's circle! With cutting-edge technology that includes telemetry capability, the 4PLS provides racers real-time data along with secure, confident control.

- T-FHSS (Telemetry), FHSS and S-FHSS capable
- 40 model memory
- 10-character model naming
- 10-character user name
- Large 128 x 64 backlit LCD display with adjustable contrast
- Adjustable alarm
- User updatable software (using CIU-2)
- Steering wheel/trigger adjustment
- Digital trims
- Model data transfer
- Model copy
- Model clear
- MC link
- Failsafe on all channels

The 4PLS also features all this:

- 100 lap memory
 - Lap timer
 - Count up/down timers
 - Wheel/trigger tension adjustment
 - Display-only mode of operation
 - Steering/throttle calibration menu
 - Dry cell, LiFe and NiMH battery compatible
 - Built-in charge jack
 - Adjustable trim steps
 - Anti-skid braking system (ABS)
 - Throttle acceleration
 - Throttle speed
 - Steering speed
 - Idle up
 - Throttle preset (hold)
 - Trim switch/dial/switch assignability
 - Mechanical ATL adjustment
 - Dual rates
 - Exponential rates
 - Servo reversing
 - Subtrim
 - End point adjustment
- Mixing Functions:**
- Brake bias mixing
 - 4-wheel steering mixing
 - Dual ESC mixing
 - Gyro mixing
 - Programmable mixing



View live data such as voltage, temperature and rpm in real time.



Set audible alarms to alert you to low battery voltage or high temps.



The included telemetry-enabled R304SB receiver features an S.Bus2 port.



Record important data for future reference, at downloadable intervals that you set.



FUTK1410
4PLS 4-Channel 2.4GHz Computer Radio System w/Telemetry

Futaba

From the Experts:

There's never been a 4-channel system with as much going for it as the 4PLS! Telemetry capability opens up a whole new world of information — including voltage, temperature and rpm readings — and it can all be viewed in real time and recorded for future reference. That's in addition to all of the 4PLS's many other functions, and for the same price as the original 4PL!

Long story short...

Aspiring drivers will love the control, convenience and sophistication of the 4PLS!



SUPER-FAST SPEEDS AND RESPONSIVE HANDLING!



GP-1 ULTRA

Packed with premium performance parts

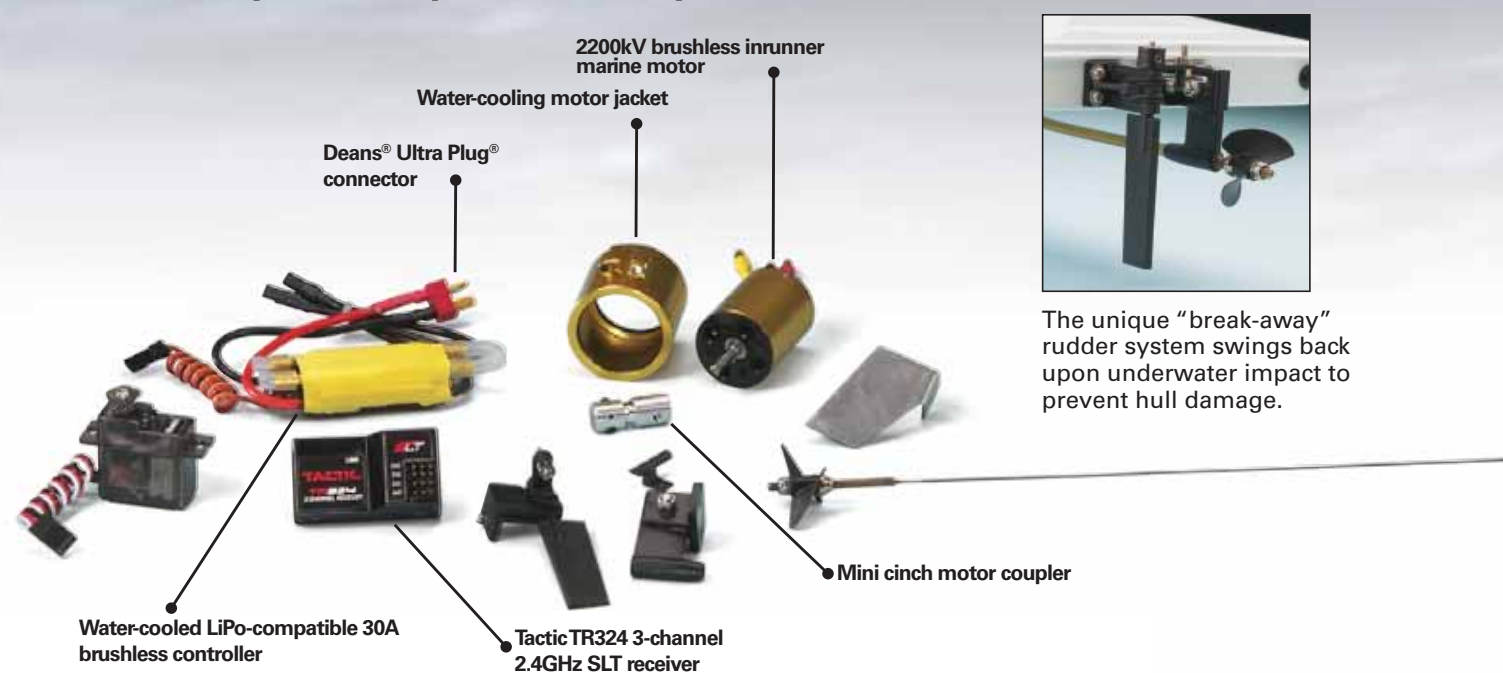

The unique "break-away" rudder system swings back upon underwater impact to prevent hull damage.

- Water-cooled 28-35-2200kV 6-pole inrunner brushless marine motor
- 28mm CNC water cooling jacket
- Water-cooled 30A controller designed for LiPo batteries
- Tactic TTX240 SLT transmitter with TR324 SLT receiver
- Kick-back rudder system
- Performance tuned ABS hull
- Foam floatation
- Mini drive wire motor coupler
- Mini Hydro turn fin
- FRP prop with standard 1/8" prop shaft

AQUB1820 GP-1 Ultra Brushless Mini Hydroplane 2.4GHz RTR
 AQUB1821 GP-1 Ultra Brushless Mini Hydroplane Rx-R
Hull Length: 16.4 in (416 mm)
Overall Length: 18 in (458 mm)
Width: 8.8 in (223 mm)
Height: 4 in (102 mm)
Weight: 14.4 oz (408 g)



Deans® and Ultra Plug® are registered trademarks of W.S. Deans Co. U.S. Patent No. 5,533,915.

From the Experts:

As the first mini hydroplane model that's both brushless AND LiPo ready, the GP-1 Ultra one-ups the compact racing boat competition! You'll enjoy super-fast speeds and responsive handling, on lakes and ponds of all sizes. The GP-1 Ultra comes factory-finished, so you can be out on the water in no time, with your choice of one equipped with a 2.4GHz radio system or one ready to accept your favorite radio system.

Long story short...

The GP-1 Ultra Brushless Mini Hydroplane is a blast to drive for boaters of all skill levels – and a great value too!



FLY A HIGHLY DETAILED MODEL OF THE ARMY'S MOST VERSATILE HELI!



The BLACK HAWK's amazing detail can be seen from any angle, and features scale touches such as an injection-molded body with rivet details, radio antennas and 3 LED lights. You'll also notice a scale 4-bladed rotor head, windshield wipers, exit door grabs, engine intakes, scale landing gear and rubber tires.

- Realistic 4-blade collective pitch rotor head
- Highly detailed scale fuselage
- Tube driven, variable pitch tail rotor system
- TAGS (Three-Axis Gyro System)
- Magnetic hatch conceals electronics while preserving scale lines
- Scale rotor blades
- Metal head block
- Includes a 7.4V 600mAh 25C 2S LiPo battery and A/C wall charger



Total control — to the 3rd power!

TAGS does far more than any single-axis gyro. It simultaneously controls the yaw, pitch and roll axes of your heli, to provide stability no single-axis gyro can match. With TAGS, you can fly with confidence because it detects external forces and compensates to ensure that they won't affect performance. The result: smoother flight and a locked-in feel to the controls. It's standard equipment on the BLACK HAWK heli — and once you've experienced TAGS, you won't ever want to fly without it!

BLACK HAWK and the Black Hawk helicopter design are trademarks of Sikorsky Aircraft Corporation. They are licensed throughout the world to Shanghai Nine Eagles Electronic Technology Co., Ltd.

BLACK HAWK

1/43 Scale Brushless Aerobatic Helicopter



With a collective pitch rotor head and variable pitch tube-driven tail rotor, combined with the TAGS 3-axis gyro, this BLACK HAWK delivers smooth scale flight right out of the box, with the capability for fully aerobatic maneuvers.



A magnetic hatch in the nose removes quickly for easy battery changes and access to the brushless outrunner motor, 3 digital servos and high speed digital tail rotor servo.

Tx-R
TRANSMITTER-READY

RTF
READY-TO-FLY

HMXE0838 BLACK HAWK 1/43 CP 4-Blade Brushless Heli RTF
HMXE0839 BLACK HAWK 1/43 CP 4-Blade Brushless HeliTx-R
Rotor Diameter: 12.8 in (324 mm)
Flying Weight: 7.4 oz (210 g)
Length: 13.8 in (350 mm)

Heli-Max[®]

From the Experts:

The full-size UH-60 BLACK HAWK helicopter does it all — and when it comes to scale detail, Heli-Max's R/C replica of the BLACK HAWK has got it all! From the rotors to the rubber tires, this bird is the spitting image of the original...and it performs just as scale as it looks. Plus, you can choose from the all-inclusive Ready-To-Fly model or the Transmitter-Ready version that you can fly with your favorite transmitter!

Long story short...

Whether on display or on a mission, this BLACK HAWK heli will make you proud!

READY TO RUN
**JEEP®
 WRANGLER
 WRAITH™**
**POISON SPYDER
 ROCK RACER**
 1/10th SCALE ELECTRIC 4WD

POISON SPYDER
 C U S T O M S



Jeep and related logos, vehicle model names and trade dress are trademarks of Chrysler Group LLC and used under license by Axial Inc. ©2013 Chrysler Group LLC.
 BFGoodrich® Tires Trademarks are used under license from Michelin.



- Officially licensed Trail Ready HD Series beadlock wheels
- Three piece IFD™ (Interchangeable Face Design) beadlock wheel system
- Adjustable breather hole design to control amount of passing air
- Officially licensed BFGoodrich Krawler™ T/A® KX tires
- 4-Link suspension, optimized to reduce axle steer
- Easy diff access for maintenance by removing four screws
- AE-2 ESC with drag brake featuring LiPo cutoff

- Protective transmission cover to keep dirt and debris out of your gears
- Performance competition shocks featuring threaded shock bodies
- Protective electronics box designed to keep receiver away from dust and debris
- The AR60 OCP-Axle (off center pumpkin design) gives you more ground clearance and a better driveshaft angle

AXID9031 Jeep Wrangler Wraith™-Poison Spyder Rock Racer RTR
Length: 19.25 in (489 mm)
Width: 11.22 in (285 mm)
Height: 9.1 in (232 mm)
Weight: 5.45 lb (2.47 kg)
Wheelbase: 13.98 in (355 mm)
Ground Clearance: 2.8 in (71.6 mm)

For additional items see a complete list at www.GPDealer.com



From the Experts:

Axial has joined forces with several of the most recognized names in off-roading – to include Jeep® Wrangler and Poison Spyder. The Jeep® Wrangler Wraith, Poison Spyder Edition was designed to resemble its full sized "scale/1:1" counterpart. We have teamed up with the extremely talented Poison Spyder Race team to bring you the latest version of the wildly popular Axial Wraith. Loaded with brand new features, this vehicle is bred for rock racing.

Long story short...

This new Jeep® Wrangler Wraith is right at home ripping across the desert at high speeds, or tackling even the toughest terrain with ease.

OFFICIALLY LICENSED TECHNICAL PARTNERS:



A BRUSHLESS COMPETITION BUGGY WITH RACE SPEC RTR EASE!

www.gpdealer.com

www.gpdealer.com



B4.2RS

RACE-SPEC

1/10 Scale Brushless Electric 2WD Buggy RTR

- Fully assembled 2WD buggy based on the 5-time I.F.M.A.R. World Champion and 10-time R.O.A.R. National Champion platform
- Powerful Reedy 3300kV brushless motor
- Heavy-duty sealed gear diff with adjustable slipper clutch
- Rugged steel turnbuckles for adjustable camber and front toe-in
- Vertical ball ends for roll center adjustments, front and rear
- High-traction compound tires pre-mounted on white hex drive wheels
- Factory finished Interceptor 2.0 polycarbonate body



XP 2.4GHz 2-channel radio system with digital metal gear servo.



Fluid-filled blue aluminum v2 shock bodies front and rear.



Water-resistant XP SC500-BL ESC with LiPo cutoff and Deans® Ultra Plug® connector. Deans® and Ultra Plug® are registered trademarks of W.S. Deans Co. U.S. Patent No. 5,533,915.



Shown equipped with a Reedy WolfPack battery pack not included.



Hex drive wheels front and rear.



Water-resistant enclosed receiver box.

ASCD93** RC10B4.2RS Race Spec 1/10 Scale Brushless Electric 2WD Buggy RTR
 Length: 14.8 in (377 mm)
 Width: 9.8 in (250 mm)
 Weight: 3.3 lb (1530 g)
 Wheelbase: 10.75 in (273 mm)

Long story short...

Drive a Race Spec RTR version of a proven championship-winning electric buggy: the RC10B4.2RS!



NEWPRODUCT

ENJOY RACE SPEC RTR CONVENIENCE WITH THIS BRUSHLESS RACE TRUCK!

NEWPRODUCT

www.gpdealer.com

www.gpdealer.com



T4.2RS RACE-SPEC

1/10 Scale Brushless Electric 2WD Truck RTR

- Fully assembled 2WD truck based on the 8-time R.O.A.R. National Champion platform
- Powerful Reedy 3300kV brushless motor
- Heavy-duty sealed gear diff with adjustable slipper clutch
- Rugged steel turnbuckles for adjustable camber and front toe-in
- Vertical ball ends for roll center adjustments, front and rear
- High-traction compound tires pre-mounted on white hex drive wheels
- Factory finished Interceptor – T polycarbonate body



Reedy 3300kV brushless motor.



XP 2.4GHz 2-channel radio system with digital metal gear servo.



Tunable suspension with rugged steel turnbuckles.



Water-resistant XP SC500-BL ESC with LiPo cutoff and Deans® Ultra Plug® connector. Deans® and Ultra Plug® are registered trademarks of W.S. Deans Co. U.S. Patent No. 5,533,915.

Shown equipped with a Reedy WolfPack battery pack, not included.

ASCD73** RC10T4.2RS Race Spec 1/10 Scale Brushless Electric 2WD Truck RTR
 Length: 15.3 in (390 mm)
 Width: 12.4 in (316 mm)
 Weight: 3.87 lb (1756 g)
 Wheelbase: 11.3 in (288 mm)



Water-resistant enclosed receiver box.

Long story short...

The RC10T4.2RS combines brushless performance with Race Spec RTR ease!



THE PERFECT WAY TO GET INTO 1/8 SCALE NITRO BUGGIES!



RC8.2
RACE · SPEC

As the winner of the 1/8 Scale R.O.A.R. Off-Road National Championship, the Dirt Nitro Challenge and the Silver State Nitro Challenge, the RC8.2 has established itself as the nitro buggy to beat! Now it's available in a Race Spec version with virtually all of the kit's features in a Ready-To-Run model designed to get you out and about in no time!

- Powerful Reedy .21VS engine with pull start and 2-chamber tuned exhaust
- XP 2.4GHz radio system with high-torque MG steering servo and water-resistant receiver box
- 16mm Big Bore 6061 aluminum shock bodies and caps with rubber shock boots
- Low CG 3mm thick 7075 aluminum shock towers
- Black hard-anodized 7075 aluminum chassis
- Updated RC8.2 racing suspension geometry
- Durable aluminum steering knuckles
- Two factory finished RC8 body color schemes to choose from

ASCD89** RC8.2RS Race Spec 1/8 Scale Nitro 4WD Buggy RTR
 Length: 18.5 in (470 mm)
 Width: 12 in (305 mm)
 Weight: 7.8 lb (3570 g)
 Wheelbase: 12.7 in (323 mm)



Powerful Reedy .21VS engine with pull start.



High-torque XP DS1510MG metal gear steering servo.



16mm Big Bore 6061 aluminum shock bodies and caps with rubber shock boots.



Aluminum steering knuckles for improved durability.

Long story short...

With the RC8.2RS RTR you can have the same proven performance features of the RC8.2 in a Race Spec Ready-To-Run!



A STUNNING REPLICAF OF BRITAIN'S FINEST FIGHTER **SPITFIRE**

Giant Scale Spitfire
Almost-Ready-to-Fly
55cc Gasoline-Powered Warbird



- Built-up and sheeted airframe, finished in flat MonoKote film
- Pre-hinged control surfaces and painted fiberglass parts reduce assembly time
- Designed to accept Robart® retractable landing gear for the ultimate in realism; landing gear covers are included with the model
- Many scale touches can be found on the molded fiberglass cowl, such as side-mounted exhaust stacks; a painted aluminum spinner is also included
- The cannons and antenna mast add more authenticity, and can be easily removed for transportation to and from the field
- Matte-finish decals let you customize your Spitfire to look exactly like the full-size fighter

TOPA0708 Giant Scale Spitfire ARF

Wingspan: 86.5 in (2195 mm)

Wing Area: 1325 in² (85.5 dm²)

Weight: 22-24 lb (10-10.9 kg)

Wing Loading: 38-42 oz/ft² (116-128 g/dm²)

Length: 72 in (1830 mm)



Plenty of details can be found in the Spitfire's cockpit, including recessed gauges, control stick, a pilot's seat and side panels.
Pilot not included.

From the Experts:

The Spitfire's speed, firepower and technology helped the Allies gain air superiority during World War II, and Top Flite's Giant Scale R/C model captures every impressive detail of this elite warbird. The scale realism is amazing, and in the air this ARF's handling is smooth and responsive.

Long story short...

This Giant Scale Gold Edition Spitfire ARF will be a proud addition to your hangar!



SINGLE CYLINDER POWER THAT'S SURPRISINGLY SMOOTH

DLE-85 Gasoline Engine

- Includes an engine mount specially designed to dampen vibration
- An exhaust extension on the included muffler aids in installation and helps protect the engine and muffler in the event of a hard landing
- The ignition module will accept input voltages from 4.8V to 8.4V, and will accept the optional DLE tachometer (DLEG5525)
- Suggested prop sizes: 25 x 10, 26 x 9, 27 x 8

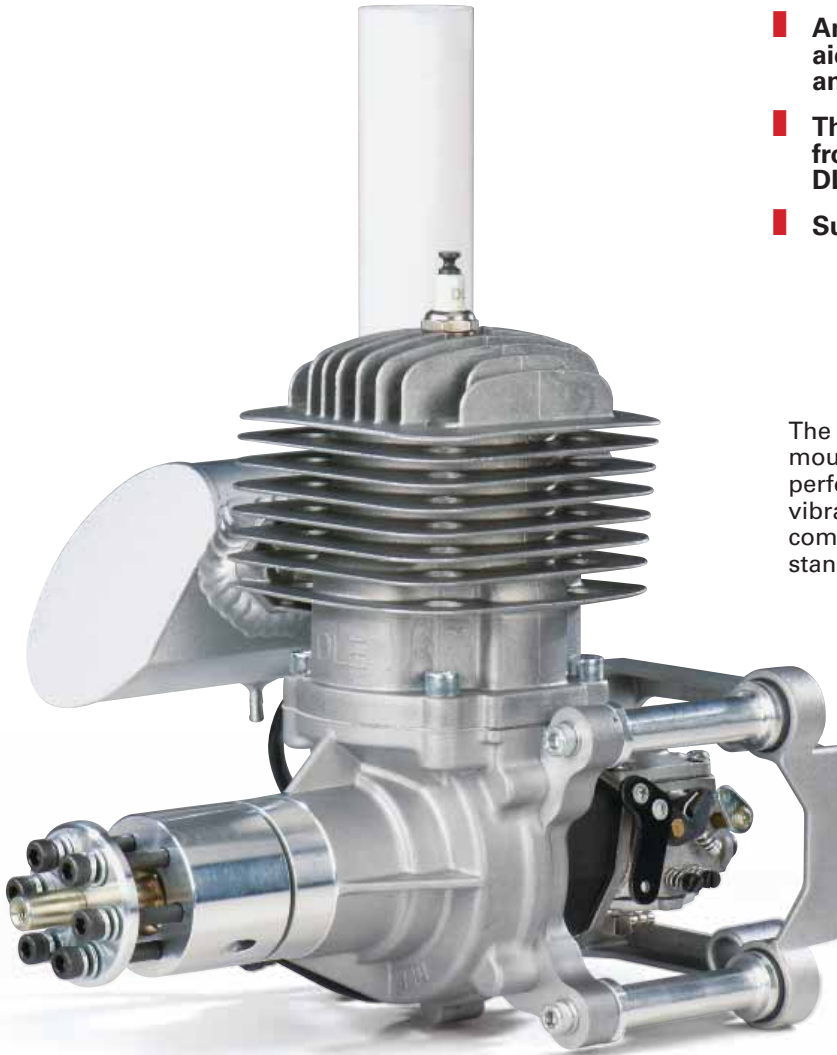

The DLE-85's engine mount combats performance-robbing vibration, and unlike comparable engines, is standard equipment.



With the DLE-85 you get a spark plug, ignition module, engine standoffs, vibration-dampening engine mount and muffler with exhaust extension.

DLEG0085 DLE-85 85cc Gasoline Engine
Displacement: 84.88 cc (5.18 cu in)
Bore: 2.047 in (52 mm)
Stroke: 1.574 in (40 mm)
Total Weight: 5.09 lb (2.31 kg)
Output: 8.5 hp @ 7500 rpm



From the Experts:

Vibration can be a real concern for a single cylinder engine of this size, but the DLE-85 keeps it in check with an included vibration-dampening engine mount. An extension on the exhaust lessens the chances of having to modify the cowl, and will flex or pop off during a hard landing, helping to protect the engine.

Long story short...

Giant-scale enthusiasts will appreciate the DLE-85's impressive power — and it's a great value as well!



NEW PRODUCT

www.gpdealer.com

EXCITING QUAD-ROTOR FLYING ANYWHERE, ANYTIME

Estes Control Dart™ Quadcopter 2.4GHz RTF

DART



The Dart comes with everything you see here!

- Flies easily in any open indoor area
- A gyro provides smooth, stable flight
- Small LED lights let you fly in the dark
- Powered by an included LiPo flight battery
- Recharges with the included USB charge cord
- 2.4GHz controller allows multiple aircraft to fly together
- Four spare rotor blades are included

ESTE4605 Dart Quadcopter 2.4GHz RTF
Rotor Diameter: 2.1 in (54 mm)
Weight: 0.9 oz (25.5 g)
Length: 4.6 in (118 mm)

From the Experts:

The Dart packs hours of flying fun into one ready-to-fly package that fits in the palm of your hand. Quad rotors make it highly maneuverable for indoor flight, including flips and rolls — while the internal gyroscopic stabilizer also lets you fly outdoors in light winds. And blue LED “eyes” on the front allow for flying the Dart in the dark!

Long story short...

Pick up the Dart today and you can be out flying before lunch!



AN IDEAL WAY TO GET INTO HELI FLYING!

Mad Cat Electric Heli RTF

- Comes fully assembled and ready to fly
- A gyro provides smooth and stable flight in any open indoor area
- Flies in all directions on command
- Lights add to the fun when flying in the dark
- Connects to the controller for fast recharging
- Features 3-channel IR control, and includes LiPo flight battery, 4 spare main blades and spare tail rotor

ESTE4601 Mad Cat Electric Heli RTF

Length: 8.6 in (218 mm)

Width: 1.4 in (36 mm)

Height: 3.9 in (99 mm)



Long story short...

The Mad Cat's coaxial rotor design makes it a breeze for anyone to fly!



Just Released



COXP1005
Super Power
1/2A Fuel-Quart

Cox® Super Power™ 1/2A Fuel

Specially formulated for 1/2A engines

- Meets the highest quality standards for 1/2A model engines
- Premium blend 25% nitro formula delivers optimal performance along with easy starting
- Special 18% oil package includes the latest high-tech synthetics combined with castor to protect and lubricate the aluminum journals and steel bearings used in small displacement engines
- Ideal for airplanes, cars or boats
- Available in value-priced quart size bottles

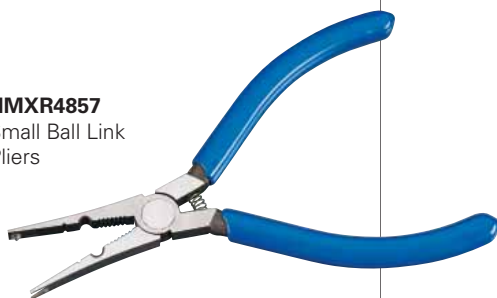

HMXR4857
Small Ball Link
Pliers

Heli-Max® Small Ball Link Pliers

No heli flight box is complete without these!

- Designed to work with most popular small electric helicopters
- Precision engineered for quick and easy removal of plastic ball links
- Also provides a secure, non-slip hold when adjusting pushrods and ball ends
- The toothed portion will grip linkage rods during rod end adjustments

NEW SCX10 OPTION PARTS!

Axial Officially Licensed Icon Vehicle Dynamics™ Products



ICON ALUMINUM SHOCK SET

CNC machined pistons, shock bodies and reservoirs for a precise fit

Polyoxymethylene - (POM/thermoplastic) shock pistons offers smooth action

Clear anodized shock bodies and reservoirs

Titanium nitride coated shock shafts for durability

- AXIC3103 Icon Aluminum Shock Set 61-90mm (2)
- AXIC3130 Icon Anodized Alum Shock Body 10x38mm (2)
- AXIC3131 Icon Anodized Aluminum Shock Reservoir (2)
- AXIC3132 Machined Shock Piston 7mm 1.5x3 (4)



ALUMINUM SHOCK BODIES

Compatible with all SCX10™ vehicles as a direct replacement

CNC machined for precision

Titanium Clear anodized for durability

Threaded body for easy height adjustment

Two shock bodies per package



ICON ALUMINUM SHOCK RESERVOIRS

Compatible with all SCX10™ vehicles as a direct replacement

CNC machined for precision

Two reservoirs per package

Includes Icon Vehicle Dynamics™ decals



MACHINED SHOCK PISTONS

Compatible with all SCX10™ vehicles as a direct replacement

CNC machined for precision

Polyoxymethylene - (POM/thermoplastic) shock pistons offer smooth action

Four pistons per package

Long story short...

Add even more scale realism to your rig with Icon Vehicle Dynamics™ parts!

ONYX QUALITY COMES TO ALKALINE BATTERIES

1.5V AA Alkaline Battery



- Built to last, with excellent storage life
- 1.5V of power, with 0% mercury, cadmium or lead
- Ideal for transmitters, as well as radios, remote controllers and cameras
- Available in convenient packages of 4, 8 and 48

- DTXP4704 Onyx 1.5V AA Alkaline Battery (4)
- DTXP4708 Onyx 1.5V AA Alkaline Battery (8)
- DTXP4748 Onyx 1.5V AA Alkaline Battery (48)



Long story short...

See the performance and dependability difference Onyx makes with this AA alkaline battery!

ONYX LIPO BATTERIES THAT POUR ON EVEN MORE POWER!

35C LiPo Batteries

- Equip your ride with 35C of awesome Onyx LiPo power, with the true-rated capacities that Onyx is known for
- New 3S 11.1V 1300mAh and 2S 7.4V 2000mAh capacities come with your choice of Deans® Ultra Plug® or Traxxas® connectors, in soft cases that reduce overall size and weight
- Other Onyx 35C LiPo batteries are available in a wide variety of capacities, with Deans® or Traxxas connectors in soft cases or impact-resistant hard cases



Deans® and Ultra Plug® are registered trademarks of W.S. Deans Co., U.S. Patent No. 5,533,915.

- DTXC1930 Onyx LiPo 35C 11.1V 1300mAh 3S Soft Case Deans®
- DTXC1931 Onyx LiPo 35C 11.1V 1300mAh 3S Soft Case Traxxas — coming soon
- DTXC1936 Onyx LiPo 35C 7.4V 2000mAh 2S Soft Case Deans® — coming soon
- DTXC1937 Onyx LiPo 35C 7.4V 2000mAh 2S Soft Case Traxxas — coming soon
- DTXC1964 Onyx LiPo 35C 7.4V 5000mAh 2S Hard Case Deans®
- DTXC1965 Onyx LiPo 35C 7.4V 5000mAh 2S Hard Case Traxxas
- DTXC1966 Onyx LiPo 35C 11.1V 5000mAh 3S Soft Case Traxxas
- DTXC1967 Onyx LiPo 35C 11.1V 5000mAh 3S Soft Case Deans®
- DTXC1970 Onyx LiPo 35C 7.4V 5700mAh 2S Soft Case Traxxas
- DTXC1978 Onyx LiPo 35C 11.1V 6400mAh 3S Soft Case Deans®
- DTXC1979 Onyx LiPo 35C 11.1V 6400mAh 3S Soft Case Traxxas
- DTXC1982 Onyx LiPo 35C 7.4V 8000mAh 2S Soft Case Deans®
- DTXC1983 Onyx LiPo 35C 7.4V 8000mAh 2S Soft Case Traxxas
- DTXC1995 Onyx LiPo 35C 11.1V 8000mAh 3S Soft Case Deans®
- DTXC1997 Onyx LiPo 35C 11.1V 8000mAh 3S Soft Case Traxxas



Long story short...

With 35C of track-ripping power, these Onyx LiPo packs are raising the bar!

EXTREME SERVOS FOR EXTREME APPLICATIONS

- Designed from the ground up for industrial uses — ideal for giant scale aircraft and 1/5 scale buggies and truggies
- All-aluminum, EMI-shielded cases, solid steel gears and non-programmable digital circuitry
- The HS-900SGS provides swift speed, while the HS-1000SGT brings hefty torque; both operate on 3- and 4-cell LiPo batteries



HRCM4100 HS-1000SGT Ultra HD Full Metal Case HT Servo
HRCM4900 HS-900SGS Ultra HD Full Metal Case HS Servo

Long story short...

These Ultra HD Servos are beefed up to deliver precise performance under the most grueling conditions.



The only thing better than Team Durango RTRs...

...ARE TEAM DURANGO RTRS AT A SPECIAL LOW PRICE!

DEST210



DEST210 2WD Brushless 2.4GHz Stadium Truck RTR

Length: 16.2 in (411 mm)
Width: 13 in (330 mm)
Wheelbase: 11.1-11.4 in (282-290 mm)
TDRD02**

DEX210



DEX210 2WD Brushless 2.4GHz Buggy RTR

Length: 15.5 in (394 mm)
Width: 9.8 in (250 mm)
Wheelbase: 10.9-11.2 in (277-285 mm)
TDRD01**

DESC210



DESC210 2WD Brushless 2.4GHz Short Course Truck RTR

Length: 21.4 in (544 mm)
Width: 11.4 in (290 mm)
Wheelbase: 12.6-13.0 in (321-329 mm)
TDRD03**

now
\$289.99

Team Durango 2WD electric RTRs are already the most competitive and best-equipped RTRs in R/C, each one sharing many of the race-proven features of its corresponding kit. And for a limited time prices have been slashed on the Ready-To-Run DEX210 buggy, DEST210 Stadium Truck and DESC210 Short Course Truck — they're now available for the incredible price of just \$289.99! That makes them the best VALUE as well as the best vehicles...but this offer won't last long, so visit your local hobby retailer today!

Team Durango

Here's just some of what you'll find on Team Durango RTRs:

- ROAR-legal 13.5T Speed Passion sensored brushless motor
- "Blinky mode" ESC
- Oil-filled gear diff that's fast, strong and easy to tune and maintain
- Patented Hybrid gearbox design that offers you four motor mounting options without changing the suspension setup
- TDTX1 2.4GHz transmitter
- Compact TDRX1 2.4GHz 3-channel micro receiver
- Waterproof AD5 digital steering servo
- Hard-anodized, threaded aluminum Big Bore oil shocks

THE SAVINGS CONTINUE...FOR ONE MORE MONTH!



If you want the best deals on R/C merchandise, don't wait any longer — take advantage of super-low prices during the last month of America's Best R/C Sale!

You'll find popular products from sixteen of your favorite manufacturers — with prices slashed up to \$50 — but the sale ends June 30, 2013 so you'll want to act fast. Visit your local participating hobby retailer today and save like never before on today's hottest R/C products!

Sale prices good through
June 30, 2013
at participating retailer!
For a complete list of products on sale visit bestrc.com and click on the America's Best R/C Sale logo.

Choose from a wide variety of quality products from these manufacturers!



You won't find this many quality R/C products on sale at the same time anywhere else! This is the perfect opportunity for you to get gifts for friends and family — or to treat yourself to a new radio control model or accessories!



To locate the participating hobby retailer nearest you, visit the America's Best R/C web page on bestrc.com and click on the Find A Dealer logo. You'll find store names, addresses, phone numbers — and in some cases even a map.

REALFLIGHT[®] R/C FLIGHT SIMULATOR

AN EXTRA-SPECIAL OFFER...
THIS MONTH ONLY!

Included in the America's Best R/C Sale event is \$20 off for consumers purchasing RealFlight 6.5 — the latest version of R/C's #1 selling flight simulator!

Imagine savings \$20 on the flight simulator that gives you all this — plus a whole lot more!

- 75+ airplanes and 20+ helis — PLUS 35+ planes in the Airplane Mega Pack and 45+ helis in the Heli Mega Pack
- Over 40 flying fields
- InterLink™ Elite controller, with features such as QuickSelect, Reset and Rewind
- Welcome screen
- Smart Binocular feature

Great Planes RealFlight 6.5 with InterLink Elite Controller
GPMZ4480 RealFlight 6.5 with Airplane Mega Pack-Mode 2
GPMZ4481 RealFlight 6.5 with Airplane Mega Pack-Mode 1
GPMZ4482 RealFlight 6.5 with Heli Mega Pack-Mode 2
GPMZ4483 RealFlight 6.5 with Heli Mega Pack-Mode 1



Available at participating local hobby shops only. Void where prohibited. Some terms, conditions and restrictions apply, and only while supplies last. Suggested prices are available only at participating hobby shops in the U.S. and Canada. Local prices may vary and are set by the independent retailers. Official rules are available at bestrc.com. DLE engine eligible for a Merchandise Certificate must be purchased before June 30, 2013 and requests must be submitted by July 31, 2013.

TURN HERE FOR GENERAL HOBBY PRODUCTS

AIM FOR THE STARS THIS SUMMER.

Let Estes show you the way.

All include:

- Plastic or laser-cut wood fins
- Decals
- Recovery parachute

All require:

- Engines
- Launch pad
- Launch controller
- Igniters
- Recovery wadding
- Tools
- White or yellow glue
- Finishing supplies

Ages 10 and up. Adult supervision recommended for modelers under 12.

Almost Ready to Fly **ARF**

Very minor assembly required. Simply insert the fins into the slots and you are ready to blast off.

Skill Level **2**

Requires gluing, painting and sanding. Assembly can take up to a day.



JBR-013™

Try the futuristic paint scheme, or make your own!

Max. Altitude: 775 ft (236 m)
Height: 18.4 in (46.7 cm)
 Skill Level: 2
 ESTT3234



Firestorm™

So hot, it sizzles

Max. Altitude: 550 ft (168 m)
Height: 20.8 in (52.8 cm)
 Skill Level: ARF
 ESTT2488



Helios™

Ride into the sunlight

Max. Altitude: 550 ft (168 m)
Height: 18.2 in (46.2 cm)
 Skill Level: ARF
 ESTT2487



L.G.M. 0095™

Traverse the lunar landscape

Max. Altitude: 650 ft (198 m)
Height: 21 in (53.3 cm)
 Skill Level: ARF
 ESTT2485



Flying Colors™

A candy-coated delight

Max. Altitude: 600 ft (183 m)
Height: 21 in (53.3 cm)
 Skill Level: ARF
 ESTT2486



Accessories

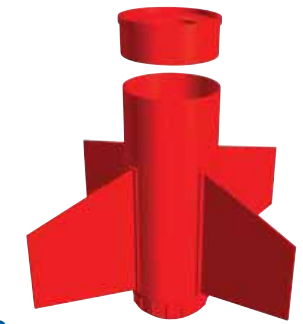

Booster-60

Raises altitude by 800 feet (244 m)!

Ideal for the Helios, Firestorm and Flying Colors

Requires: 1 D12-0 booster engine
 Skill Level: ARF
 ESTT2256



Booster-55

Add 800 feet (244 m) to your flights!

Perfect for the I.G.M. 0095 and Red Rider™

Requires: 1 D12-0 booster engine
 Skill Level: ARF
 ESTT2257



Clear Payload Section Assortment

9-piece set, 3 different sizes.

Includes BT20, BT50 and BT60 payloads
 ESTT3171

From the Experts:

Summertime is prime time for Estes rockets. Pick your favorite models from this exciting line-up today!

Long story short...

Rocketeers should run – not walk – to their hobby shop and get their hands on each one of these brand-new Estes models and accessories!

Rockets



SHIPS FROM ARTESANIA LATINA!

Celebrate the golden age of seafaring

Ship kits from Artesania Latina reflect the golden age of sail with elegant, all-wood construction and historically accurate scale sails, deck fixtures, color schemes and more. The range of ships is vast from famous warships like Hermione to great explorers like H.M.S. Endeavour. Its subjects stretch across time and space from the Junks of ancient China to modern day fishing boats on the Bay of Biscay.



Professional-Grade Tools for your Ship

The perfect tools for any job

Even the greatest harbors of the world would be nothing without tools. Luckily, Artesania Latina has a massive selection of tools available to make sure you have absolutely everything you need to make your model pristine. From simple tweezers to 45-in-1 tool kits, every tool is specially designed with one thought in mind—making your model look great.



LATB0506
20506 1/50 Marina II



LATB2401
22401 1/50 Le Renard/The Fox



LATB2418
22418 1/28 Pen Duick



LATB2517
22517 1/89 Hermione LaFayette



LATB8010
18010 1/25 San Juan Nepomuceno Cutter

LATB2516
22516 1/60 HMS Endeavour



LATB8020
118020 1/60 Red Dragon Chinese Junk



LATB8021
18021 1/50 Scottish Maid



LATB8022
18022 1/30 San Juan Galeon XVth Century



LATR7056
27056 Digital Gauger 0-12MM

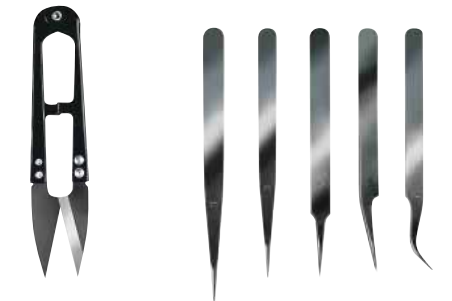

LATR7060
27060 Thread Snips

LATR7068
27068 SS X-Fine Tweezer 5Pc



LATX7026
27025-1 Magnifier W/6 Lights



LATX7055
27054-2 Mag Glasses W/LED/Lens



LATR7220
27220 Prec Tool Set 45-In-1



LATR7221
27221 Prec Tool Set 10-In-1



LATR7008
27008 Orientable Vise

Long story short...

Artesania Latina has the ships, they have the tools, they need the builders! Don't miss this opportunity to build some of history's greatest ships! See GPDealer.com for a full selection of ships and tools available from Artesania Latina.



www.revell.com

1/25 SCALE 1997 FORD® EXPEDITION POLICE INTERCEPTOR

Say hello to the bust bus

All real-leather seats, air conditioning and the smoothest suspension around; yeah the Expedition is the perfect way to go... to jail. For some law enforcement agencies in the U.S., load and passenger capacity are more important than speed. The Ford Expedition Special Service Vehicle (SSV) is perfect for those agencies. Its reliability, towing capacity, and passenger capacity are especially useful to the Border Patrol. This **kit features** an easy to assemble screw-on chassis, a painted roof light bar, interior security screens and storage compartments.

RMXS1972 Total Parts: 46 Skill Level: 1 Length: 8.3 in (211 mm)



1/24 SCALE ORIGINAL MINI COOPER®

Meet the mighty Mini

Mini Coopers were an instant hit when the British Motor Corporation released them in the early sixties. Unlike the large, big-engine cars of the U.S., the Mini Cooper was a compact vehicle equipped with a less powerful engine. They became legends, winning the Monte Carlo Rally four times and a staggering number of wins in lesser races. This **kit features** an opening hood with detailed 61 ci (998 cc) engine. It can be built for left or right hand drive and has moveable front wheels.

RMXS4035 Total Parts: 128 Skill Level: 2 Length: 5 in (127 mm)



1/25 SCALE '64 CHEVY® IMPALA™

The original low rider

Chevy Impalas have been top sellers ever since their introduction in 1958; the '64 stands out by being one of the best-selling Impalas of all time. Its low-slung chassis, powerful engine and wide wheelbase made it very popular with consumers in the mid-sixties and it is still regarded as a classic today. Today, its X frame is popular with people interested in modifying the vehicle's ride height and suspension. This **kit features** a detailed chassis with choice of suspension settings, large diameter Foose® design wheels, V-8 engine and opening trunk.

RMXS4050 Total Parts: 144 Skill Level: 2 Length: 8.5 in (216 mm)



1/25 SCALE '67 CORVETTE® STING RAY® CONVERTIBLE

Saluting the golden age of autos

By 1967, the Corvette was a well-established brand with a loyal customer following. Sting Rays were among the most popular cars ever produced. Their combination of sleek, unique body styling and massive power made them perfect for sixties-era speedsters. '67 was the last year for the Sting Ray and it incorporated some of the most awesome features to date, including 427 Big Block engines, and Tri-Power 3 carb intake systems. This **kit features** a choice of two hoods and two different wheel styles, plus a separate plated windshield frame.

RMXS4087 Total Parts: 156 Skill Level: 2 Length: 6.8 in (173 mm)





1/48 F-16® AIR TEAM

Canceled for lack of funds

The Thunderbirds, the United States Air Force Aerial Demonstration team, has wowed millions in shows all over the world for nearly sixty years, but not anymore. Budget cuts have grounded these aerial daredevils for the 2013 season and maybe beyond. If you were hoping to get a look at the stunts the fearless pilots perform, this Monogram model is probably your best bet. Build this kit and keep the memory alive! **Kit features** a detailed cockpit and landing gear, a center-mounted drop tank and wingtip missiles, plus authentic afterburner pedals.

RMXS5326 Total Parts: 77 Skill Level: 2 Length: 11.8 in (298 mm)



REVELL OF GERMANY® PLASTIC MODELS



1/72 SCALE STUG 40 AUSF. G

Nazi Germany's do-all tank destroyer

Originally designed to serve as infantry support vehicles, Sturmgeschutz IIIs became some of the most potent anti-armor weapons of World War II. Their combination of low hull profile, high-velocity gun and decent armor made them the perfect ambush vehicles. Germany could also build these vehicles quickly and cheaply, so they became the vehicle of choice for replacing losses. This **kit features** many fine details like segmented tracks, attachment points for armor skirts, engine covers and decals for two versions: Sturmabteilung 2, III Abteilung and Sturmartillerie Brigade 191.

RVLS3194 Total Parts: 148 Skill Level: 4 Length: 3.7 in (94 mm)



1/72 SCALE F-89 D/J SCORPION

Three kilotons of sting

Scorpions were the most heavily armed jet fighters ever created by the US. They were a Cold-War weapon intended to smash bomber formations inbound from Russia, so they carried the most devastating air-to-air weapons available at the time. The D versions armament—104-70 mm rockets and 16-127 mm rockets; the J version: four falcon guided missiles and two 1.5 kiloton yield Genie nuclear rockets. Far more than enough hurt to ruin any Soviet pilot's day. This **kit features** parts and weapons for either version plus decals for two USAF versions.

RVLS4848 Total Parts: 101 Skill Level: 3



1/32 SCALE BAE SYSTEMS® HAWK

From training comes triumph

Fighter pilot training is a rigorous and dangerous process that strains both man and machine. Hawks are made to take all the punishment that inexperienced pilots can cause and keep flying. That rugged dependability led the Hawk off of the training field and into the front-line air-forces of many nations. It is outpaced by many air superiority fighters but excels in the ground attack and interception roles. This **kit features** many detailed parts, air brakes, under wing pylons with rocket pods and fuel tanks, and decals for two RAF aircraft.

RVLS4849 Total Parts: 170 Skill Level: 5 Length: 14.5 in (368 mm)



www.revell.com

1/700 SCALE H.M.S. KELLY (H.M.S. KIPLING)

Keep on fighting

HMS Kelly had some of the worst luck of any ship ever launched. She was damaged by storms, collisions, mines and torpedoes all within a year of commissioning. Her crew bravely maintained their motto, "Keep on instead of hold on," and kept up the fight. Their bravery helped them down two Stuka dive bombers that were attacking the ship off Crete, but it could do nothing to keep Kelly from sinking. This **kit features** parts for either Kelly or Kipling with a waterline hull, guns, torpedo tubes and decals.

RVLS5120 Total Parts: 103 Skill Level: 3 Length: 6.1 in (155 mm)



1/700 SCALE R.M.S. OLYMPIC

Sister ship of the Titanic

Of the White Star Line's three enormous ships, (Olympic, Titanic and Britannic) Olympic was the only ship to operate for more than a year. She successfully completed so many voyages in peace and during the First World War that she was dubbed "Old Reliable". The stout ship also has the distinction of being the first merchant vessel to sink a submarine. This model is made to look like the vessel in 1911, prior to her refit after Titanic sank. This **kit features** a full hull, display stand, lifeboats and decals.

RVLS5212 Total Parts: 132 Skill Level: 3 Length: 15.2 in (385 mm)



NEW RELEASES



Hobby kits

1/12 SCALE YAMAHA® YZR500 (0W98)

"SONAUTO-YAMAHA 1988"

Score some wins with Christian Sarron

From 1973-2002, the Yamaha YZR500 led four 500 cc Grand Prix riders to ten separate world championships. One of the most famous riders to take the helm of the YZR500 was France's Christian Sarron. For the 1988 season, Sarron rode for the Sonauto-Yamaha team, scoring 149 points to earn a fourth-place finish overall. This limited edition **kit features** new front brake caliper parts and one decal marking option: 1. Sonauto-Yamaha Team 1988 WGP500, 4th Place Vehicle, No. 7 Rider: Christian Sarron.

21705 HSGS1705 Total Parts: 165 Skill Level: 3



1/72 SCALE VOUGHT F4U-1A CORSAIR COMBO

Two famous World War II fighters in one box

Marine Fighter Squadrons 111 "Devil Dogs", 212 "Hell Hounds" and 214 "Black Sheep" all operated the F4U Corsair during WWII. Their aircraft had been rejected by the Navy because of the dangers involved in landing 1As on carriers. The leathernecks didn't care. What mattered was that Corsairs were tough, agile birds that packed the punch needed to put Zeros down. By war's end, the Corsair had an 11:1 kill ratio. This limited edition kit combo features two Corsairs with decal options for the listed squadrons.

02032 (Limited Edition) HSGS2032 Total Parts: 34 x 2 Skill Level: 3





1/72 SCALE DELTA DAGGER AND DELTA DART KIT COMBO

Fly a wing team from the "Tiger Squadron"

The 460th Fighter Interceptor Squadron flew their planes out of airbases in Tennessee then Oregon in defense of strategic locations in the Cold War era. The Delta Dagger and its successor the Delta Dart were both dedicated interceptors, designed and built for the sole purpose of stopping Soviet bombers from reaching the United States. They might have been great at that role, but they never had to prove it. This limited edition **kit combo** includes both a Delta Dagger and Delta Dart with two 460 FIS decal options for each.

02035 (Limited Edition) HSGS2035 Total Parts: 67+63 Skill Level: 3



1/72 SCALE F9F-8 COUGAR COMBO

The cat with the most claws

Cougars were some of the first jet-propelled aircraft in the US Navy. They were heavily armed, with four 20 mm cannon and, eventually, the new (at the time) Sidewinder missiles. These aircraft are also remarkable in that they show the first break in the traditional straight-wing fighter layout. They are essential to the collection of anyone interested in naval aviation. This limited edition **kit combo features** a pair of Cougars with decals for three USN aircraft: VA-56 Code: NF308, VF-121 Code: D121 and VA-153 Code: H00.

02036 (Limited Edition) HSGS2036 Total Parts: 62 x 2 Skill Level: 3



1/72 SCALE KAWANISHI H6K5 TYPE 97 MODEL 23 "901ST NAVAL FLYING GROUP"

The I.J.N.'s mighty "Mavis"

The H6K was developed by Kawanishi in 1934 in response to the RAF's Short Rangoon biplane flying-boat. The first prototype took its maiden flight two years later. By 1938, the H6K was aiding the I.J.N. in the Sino-Japanese War. An ability to endure 24-hour patrols made the H6K ideal for bombing and long-range recon missions during World War II. This limited edition **kit features** new photo-etched radar parts, plus two decal marking options: 1. I.J.N. 901st N.F.G., Code: KEA-63 and 2. I.J.N. 901st N.F.G., Code: KEA-59.

02048 (Limited Edition) HSGS2048 Total Parts: 150 Skill Level: 3



1/72 SCALE TORNADO IDS "ITALIAN AIR FORCE TORNADO 25TH ANNIVERSARY"

A quarter-century of multi-role muscle

The Tornado IDS (interdictor/strike) fighter-bomber has been a favorite of air forces all over the world since its 1979 introduction. The Italian Air Force received its first fleet of one-hundred Tornado IDS aircraft in 1982 – and it hasn't looked back ever since. In 2007, the I.A.F. celebrated the Tornado's twenty-fifth anniversary of operation by adding a special "Red Devils" paint scheme to the exterior. This limited edition **kit features** one decal marking option: 1. Italian A.F. 6th Stormo, 154th Gruppo 25th Anniversary Special Marking, Code: 6-31, 2007.

02049 (Limited Edition) HSGS2049 Total Parts: 111 Skill Level: 3

1/72 SCALE MITSUBISHI® KI-46-III TYPE 100 COMMAND RECONNAISSANCE PLANE (DINAH) INTERCEPTOR "28TH FLIGHT REGIMENT"

Revel in recon with the I.J.A.A.F.

In 1937, the Imperial Japanese Army Air Force asked Mitsubishi for a long-range recon aircraft that was faster than the single-engine Ki-15. Mitsubishi responded with the twin-engine Ki-46. It proved to be highly useful during World War II. 1944's Ki-46-III variant was a high-altitude interceptor with a 37 mm cannon and twin 20 mm cannons in the nose. This limited edition **kit features** three decal marking options: 1. I.J.A.A.F. 28th F.R., 2nd Company, Code: 3; 2. I.J.A.A.F. 28th F.R., 1st Company, Code: 57 and 3. I.J.A.A.F. 17th Company Independence Flight.

02050 (Limited Edition) HSGS2050 Total Parts: 68 Skill Level: 3

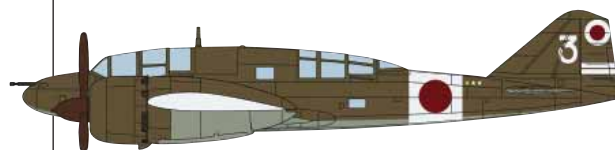

1/450 SCALE IJN BATTLESHIP YAMATO Symbol of Japanese power and spirit

Yamato was meant to symbolize Japan's dominance. She was the most powerful battleship ever built. Her main battery could engage targets 26 miles (42 km) away and her secondary battery dwarfed the firepower of most cruisers. Yamato had arrived too late, though. The battleship era was over. On April 7, 1945, nearly 400 American aircraft intercepted Yamato. After four hours of attacks, Yamato capsized and a magazine detonated, blowing the ship in half. This **kit features** a simplified build of the Yamato with a full decal set.

40151-8 HSGS4151 Total Parts: 282 Skill Level: 3 Length: 23 in (585 mm)



1/48 SCALE ARADO AR 234 C-3 "ANTI-SHIP ATTACKER"

Schnell! Mach Schnell!

Shortly after the outbreak of WWII, Nazi Germany began developing a jet engine powered bomber that could outfly any plane in the world. By 1945, the Nazis had produced an aircraft that was uncatchable, largely undetectable and capable of carrying thousands of pounds of bombs, torpedoes and guns. There was only one problem; Germany was out of gas. Most of these aircraft never left the ground. This limited edition **kit features** detailed parts for an Arado Ar 234 with an aerial torpedo and Luftwaffe decals.

07332 (Limited Edition) HSGS7332 Total Parts: 172 Skill Level: 3



1/48 SCALE MITSUBISHI® A6M2B ZERO Flown from Junyo's decks

At the outset of WWII, the I.J.N. Carrier Junyo's Zeros outclassed most aircraft that America could send against them. After the Battle of Guadalcanal, however, Junyo's fortunes took a turn for the worse. The carrier repeatedly suffered damage that necessitated long repair sessions. Her air crews fought hard, but were depleted again and again. When Japan surrendered, Junyo was little more than a floating hulk with irreparable damage and her air crews long gone. This limited edition **kit features** decals for three different Zeros from the Junyo Fighter Group.

07333 (Limited Edition) HSGS7333 Total Parts: 69 Skill Level: 3





1/48 SCALE SPITFIRE MK VI Fighters of the 616 Sq. from Dunkirk to D-Day.

Spitfires, the renowned defenders of the British home islands during World War II, were some of the most powerful aircraft of the era. South Yorkshire Auxiliary Air Squadron No. 616 flew the Spitfire in combat against Luftwaffe fighters from the withdrawal from Dunkirk in mid-1940 to the D-Day landings in mid-1944. Most critically, 616 Sq. was a key component of the defense of London during the Battle of Britain. This limited edition **kit features** a detailed Spitfire MK VI with decals for R.A.F. 616 Sq. Codes: YQ-P and AB534 1942.

07334 (Limited Edition) HSGS7334 Total Parts: 63 Skill Level: 3

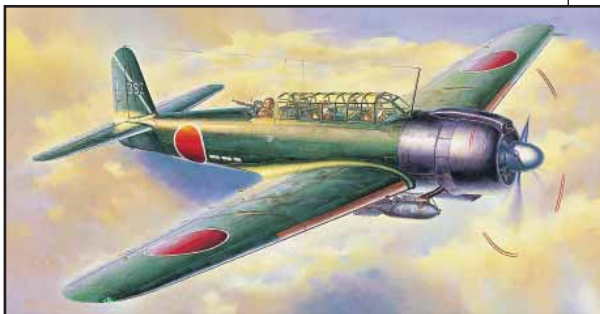

1/48 SCALE NAKAJIMA B6N1 TENZAN TYPE 11 (JILL) Carrier attack bombers of the 601st Naval Air Group

"Jill" torpedo bombers were introduced in 1943 as a replacement for the B5N "Kate". The 601st NAG flew "Jills" at the Battle of the Philippine Sea, Iwo Jima and Okinawa. Although they were faster and more maneuverable than B5Ns, B6Ns were still no match for American carrier-based fighters who had long before achieved near-total air superiority in the Pacific. Losses were so high among the aircraft that there is only one known example still in existence. This limited edition **kit features** decals for the 601st and 531st NFGs.

07335 (Limited Edition) HSGS7335 Total Parts: 170 Skill Level: 3



1/48 SCALE KAWASAKI® T-4 "BLUE IMPULSE 2012/2013" Japan's two-seat subsonic jet

Introduced in 1988, the Kawasaki T-4 is a subsonic trainer that replaced Japan's aging fleet of Lockheed® T-33s and Fuji® T-1 jets. Kawasaki produced over two-hundred T-4s for the Japan Air Self-Defense Force. The J.A.S.D.F.'s Blue Impulse aerobatic demonstration team transitioned to the T-4 in 1995. Today, the squadron has eleven T-4s in its fleet, which are usually flown in jaw-dropping formations of six aircraft. This limited edition **kit features** one decal marking option: 1. J.A.S.D.F. 4th AW 11th Sq. "Blue Impulse," 2012-2013.

07341 (Limited Edition) HSGS7341 Total Parts: 118 Skill Level: 3

Plastic Models

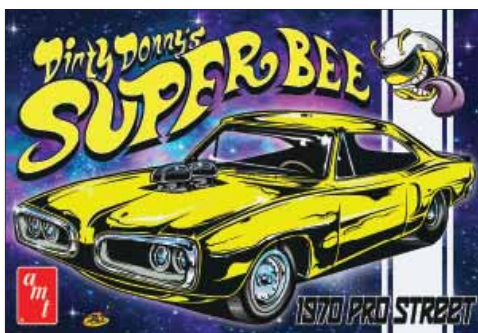

AMT® 1/25 Scale Dirty Donny 1970 Dodge Coronet Pro Street A "Super Bee" from double D

"Super Bees" were hot-rod lover's dream cars; cheap, good engines, better carburetors and plenty of room for modification. There was just no way you could go wrong. With slicks, headers and a few other choice upgrades, the Bee would flat fly. Relive the thrill of the muscle car era with this superb Super Bee kit from AMT! This **kit features** three motor intake options, super wide street slicks, narrowed rear suspension, tub chassis and a deluxe decal sheet all packaged in special Dirty Donny art packaging with a bonus sticker.

AMT806/12 AMTS0806 Skill Level: 2

Plastic Models

www.gpdealer.com

AMT® 1/25 Scale 2009 Chevy® Corvette® Indy® 500 Parade Car

Everyone loves a parade

The Chevy Corvette wouldn't stand a chance against the formula one racers of the Indianapolis 500, but they do look good at the parade. They are also some of the fastest street cars out there. Showroom Replicas™ kits, like this one, are made with completely new tooling that ensures a perfect fit for every piece and fewer parts for more efficient building. This **kit features** full color Indy 500 parade car decals, vinyl tires and seats, chrome wheels and single-piece motor and chassis details.

AMT814-12 AMTS0814 Skill Level: 2



AMT® 1/25 Scale 1972 Nova™ Beverly Hills Cop

Crime is a no-go when this cop is around

When Axel Foley left Detroit to hunt down hoods in Beverly Hills, he didn't go alone. His old blue Nova faithfully carried Axel from scene to scene despite being in an increasingly decrepit state. Now you can get the iconic car from one of the highest grossing films of all time. Make a replica of the beat up blue Nova from the film, or design it your way. This **kit features** both stock and drag parts, engine intake options, mag wheels and a detailed suspension and interior.

AMT836-12 AMTS0836 Skill Level: 2

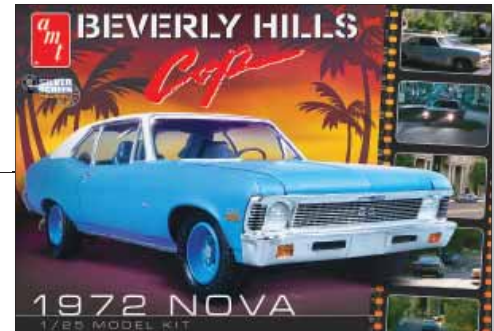

MPC® 1/9 Scale Alien™ Figure

It comes from us, to kill us

Even after thirty-four years Alien is still making audiences hide under the bed, the only problem is that's probably exactly where the alien is waiting. This model celebrates the horror, revulsion and fascination that H.R. Giger's creation inspired in millions of movie goers worldwide. Bring the creature out of the shadows where you can finally shudder in full knowledge of its intricacies. This model kit stands nine inches tall and features a highly detailed alien with pivoting neck and arms.

MPC793/12 MPCS0793 Skill Level: 2 Length: 9 in (229 mm) tall



Just Released

Model Power® HO Scale Grandma's House Built Up

You're over the river and through the woods

- Ready for installation in your layout
- Fully assembled and painted
- Two story house with roofed porch
- Includes lights and two figures



MDPU0779
HO Scale Grandma's House Built Up

Model Power® HO Scale Jackson's House Built Up

Two story country manor on quiet lot

- Ready for installation in your layout
- Fully assembled and painted
- Two story house with roofed porch
- Includes lights and two figures



MDPU0781
HO Scale Jackson's House Built Up



MDPU0784
HO Scale
Stevenson's House
Built Up

Model Power® HO Scale Stevenson's House Built Up

Attractive two story red brick home

- Ready for installation in your layout
- Fully assembled and painted
- Two story house with roofed porch
- Includes lights and two figures



MDPU5342
1/100 Scale P-51D
Mustang "Tuskegee
Airmen"

Model Power® 1/100 Scale P-51D Mustang "Tuskegee Airmen"

'Red-Tailed Angels'

- Fully assembled and detailed die-cast model
- Includes display base with engraving
- Mustang has distinctive red tail of the "Tuskegee Airmen"
- Includes historical details of the Mustang and Tuskegee pilots

Estes® Zip Disc™ Sport Set

Glides on a cushion of air!

- Hockey made high-tech – no ice required
- Infinite playing potential, indoors or out
- Sports set includes 1 Zip Disc™, 2 hockey sticks and 2 goals
- Requires 4 "AA" batteries; 2 players; 8+

Bottles not included



8311
ESTH8311
Zip Disc™ Sport Set

NEWPRODUCT

NEW FROM ROUND 2

Lindberg Models join the Round 2 catalog

Lindberg Models has been a major producer of plastic model kits since 1947. Their kits cover nearly every genre: science and education, aircraft models, civilian vehicles, military vehicles, ships, space and sci-fi, even dinosaurs. The addition of Lindberg to the Round 2 lineup offers hobbyists a great new opportunity to get model kits you won't see anywhere else.

Science and education models

Curious about the way things work? Science and education models let you get a good look at brains, hearts, lungs, aliens and much more from the inside out.

Aircraft models

From legendary favorites like the B-17 to lesser-known war planes like the Handley-Page Victor, Lindberg has some of the most detailed aircraft models on the market.

Vehicle models

Got a need for speed? Pick up a 1/12 scale Fiat® dragster or go for the nostalgia of the '31 Bugatti Royal Victoria. Whatever you choose, with Lindberg, you're choosing quality.

Ship models

Scour the seas of lubbers with Blackbeard, Kidd, and Sir Henry Morgan. Or sail into some of the fiercest sea battles in history with the Bismarck and Hood.

Military vehicle models

Cars that swim, missiles that miss and artillery that's horsing around—Lindberg has a fine selection of great military vehicles that history has largely forgotten.

Sci-fi figure models

Explore worlds and times beyond our own with Lindberg sci-fi models. Dinosaurs, aliens, spacecraft are all at your fingertips. Plus, examine the intricacies of old firearms!

The collage displays a wide variety of Lindberg model kits. At the top left is the 'VELOCIRAPTOR RAPTOR' dinosaur kit. Next to it is 'THE CIVIL WAR CONFEDERATE HORSE DRAWN FIELD ARTILLERY'. To the right is the 'P-47 THUNDERBOLT A4D-1 SKYHAWK HEINKE'. Below these are 'AVRO VULCAN', 'F-86A SABRE', and 'JOHN F. KENNEDY'S PT-109'. The middle section features 'ROSWELL UFO 1952 CHEVY FASTBACK', '1925 FORD MODEL T STREET ROD', 'F-150 FLARESIDE 4X4', and '40 FORD COUPE'. The bottom section includes '1929 "T" ROD', 'AMERICAN LAFRANCE 900 PUMPER FIRE ENGINE', 'VOOKER CHEVROLET VEGA', 'FIREPOWER SERIES F-100D SUPER SABRE', 'CURTISS JENNY', 'FORD CROWN VICTORIA', 'DODGE CHARGER', 'DODGE CHARGER', 'DODGE RAMINAL', 'HOT CANARY "T"', 'DODGE L-700 & '40 FORD COUPE WITH FLATBED TRAILER', 'DODGE L-700 CHROME TANKER', 'FIREPOWER SERIES TBF AVENGER', 'FOCKE WULF FW190', 'BLACKBEARD Captain Edward Teach', and 'OFF-ROAD 4X4 F-150'. A large 'LINDBERG' logo is prominently displayed in the upper right quadrant of the collage.

TURN HERE FOR RADIO CONTROL PRODUCTS

Long story short...

Whether you're looking for the frivolous or the momentous, the interesting and the unique, Lindberg has it. Check out GPDealer.com for a full list of available Lindberg models.