

# GREAT NEWS<sup>®</sup>

GREAT PLANES MODEL DISTRIBUTORS

RADIO CONTROL • OCTOBER 2011

Reset.  
Rewind.

**REALFLIGHT<sup>6</sup>**  
R/C FLIGHT SIMULATOR

Pages 2-5



RESET

**PLUS:**

Sneak Peak at the  
New Duratrax<sup>®</sup> line

Pages 6-9

Introducing the  
Innovative ARRMA line

Pages 10-12

Free Merchandise

Pages 29-33



# GREAT NEWS<sup>®</sup>

GREAT PLANES MODEL DISTRIBUTORS

GENERAL HOBBY • OCTOBER 2011

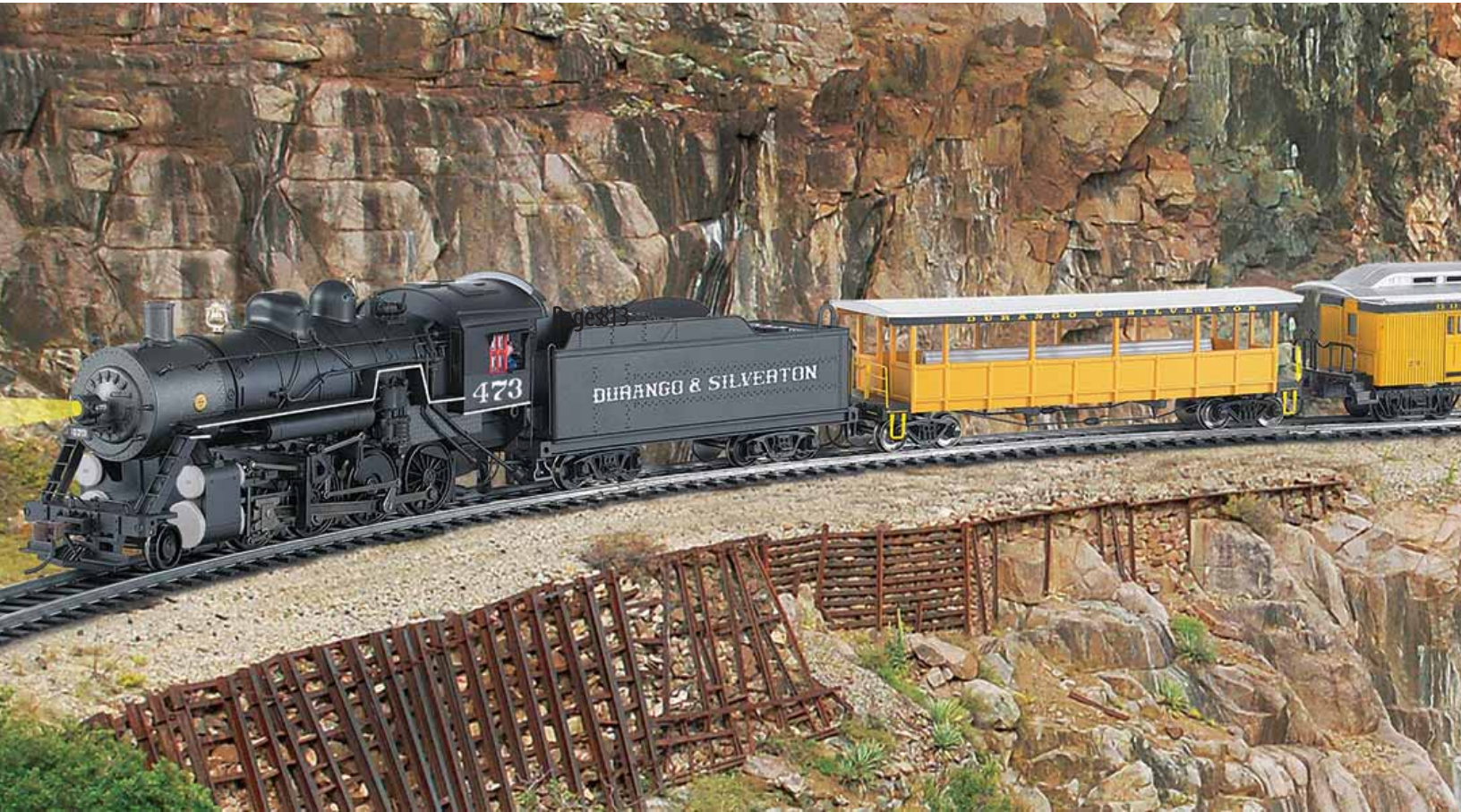

## Durango & Silverton Set H0

Page 13

# BACHMANN

### PLUS:

#### New Plastic Models

Pages 2 – 10

#### New Bachmann Sets

Pages 13&14

#### SCX<sup>®</sup> Moto GP Set

Page 11

**Hasegawa**  
Hobby kits

## PHOTO CONTEST

Enter photos of your models to win a \$50 merchandise certificate!

Page 8

# WITH REALFLIGHT, CRASHING IS

**RealFlight** is absolutely the best flight training available! With **RealFlight** you can learn how to fly and sharpen your skills without the risk (and expense!) of real crash damage. Let **RealFlight** be your training tool, so you're not the one saying "I should have learned on **RealFlight**".



Whether you're a veteran pilot or just interested in finding out more about radio control, **RealFlight** is the perfect tool.

The physics and the graphics are so accurate, it's just like flying the actual airplane or heli.

And **RealFlight** offers so many choices in aircraft, flying sites and customization, there's virtually no scenario you can't recreate!

## It's educational!

Learn to fly R/C risk-free, either by trial and error or with the help of virtual flight instructors. Practice takeoffs and landings, work on perfecting precision maneuvers and routines, or anything you would do with your actual model — without worrying about damaging it.

- Absolutely the best way to learn to fly

## It's FUN!

RealFlight is a relaxing way to experience R/C. Enjoy leisurely solo flights, tackle aerial obstacle courses, even engage in combat with friends online.

- Paintball
- Streamer Cut
- Machine Gun
- Multiplayer

# REALFLIGHT<sup>6</sup>

R/C FLIGHT SIMULATOR<sup>®</sup>

What makes RealFlight the #1 flight sim?

- Over 85 aircraft included; hundreds more available
- More than 30 PhotoField™ and 3D flying sites
- Reset Button
- Rewind feature
- Online multiplayer
- Game-style combat events
- Onboard cameras
- Night flying
- Water takeoffs and landings
- "Full coverage" collision detection
- Training aids, including Virtual Flight Instructor
- Unlimited customizing for flying sites and aircraft
- Depth of Field effect
- Orientation aids, including Overhead View, Wing Tip Trails and Sky Grid
- Enhanced visual effects
- Quick Load and Quick Edit



"I should have learned on RealFlight"

# NOT AN EXPENSIVE MISTAKE

## True to Life™

### It's even more realistic!

Turn the page to find out more about the latest and greatest generation of flight sim technology yet: RealFlight 6. Not only have the physics and the InterLink® Elite controller been made even more realistic, there are lots more aircraft to choose from.

- Incredible heli physics
- Bonus Mega Packs included – FREE
- Lots of new features



...ned on RealFlight!™

Take a test flight at your hobby dealer today!

# REALFLIGHT 6

R/C FLIGHT SIMULATOR

# PREPARE

**True to Life™**

**NOW WITH REWIND**

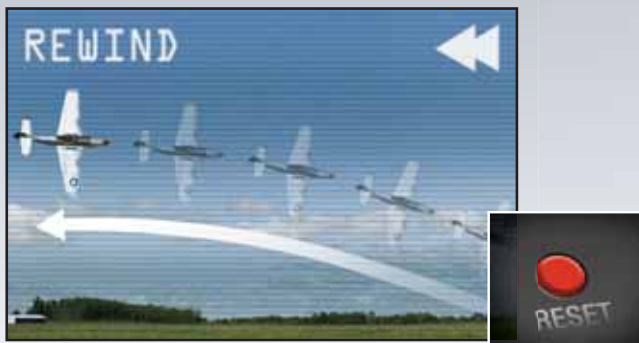

**The only sim with a Reset Button!**

The Reset Button really sets RealFlight apart from all the other sims. Push it after a crash and you're instantly ready for your next flight.

And now there's instant Rewind, too! Just hold down the Reset Button to rewind your current flight and start flying again from any point.

**MORE NEW FEATURES**

**Safety Alerts**

Provides a checklist of safe flying practices you should follow when flying your actual R/C model.

**Quick Load**

Makes loading a new aircraft or flying site super-fast. Just start typing the name, and choices are instantly displayed for you to select.

**Quick Edit**

Make simple changes to a RealFlight aircraft that will accurately reflect the flight characteristics of your actual R/C model — in just a couple of keystrokes.



**INCLUDES BONUS MEGA PACKS**

Imagine flying a different plane or heli every day for months; with RealFlight 6 you can! In addition to over 85 models with the RealFlight 6 software you also get your choice of an Airplane Mega Pack with 36 extra planes or a Heli Mega Pack with 47 additional helis.



**FREE with RealFlight 6!**



*Choose extra airplanes or extra helis!*

# TO BE BLOWN AWAY!

## VASTLY IMPROVED HELI PHYSICS



Incredibly realistic crash results

RealFlight 6 is now loaded with even more realism throughout and vastly improved heli physics!

Expert pilots Brian Bremer, Matt Botos, Bobby Watts and others worked with the RealFlight engineers to program increased precision and incredible heli performance. These experts made sure RealFlight reacts exactly like real life -- more true-to-life crash results and more precise heli flight characteristics. The feel and response is as real as it can possibly get.



Blade stop autos

## NEW HELI VERSION CONTROLLER

### A more intuitive InterLink® Elite Heli Version Controller

The RealFlight 6 version that comes with the Heli Mega Pack now also features a controller that's configured like a heli transmitter! The switch and rotary knob for Channels 6 and 7 are positioned where they appear on all heli radios, and eliminated the ratchet from the throttle stick.



- GPMZ4460 RealFlight 6 w/Airplane Mega Pack Mode 2
- GPMZ4461 RealFlight 6 w/Airplane Mega Pack Mode 1
- GPMZ4462 RealFlight 6 w/Heli Mega Pack Mode 2
- GPMZ4463 RealFlight 6 w/Heli Mega Pack Mode 1

**Also available:** Airplane and Heli Mega Packs separately!  
 GPMZ4160 RealFlight 6 Airplane Mega Pack Only  
 GPMZ4162 RealFlight 6 Heli Mega Pack Only

**Upgrade your existing RealFlight to RealFlight 6!**  
 If you have RealFlight G4, G4.5, G5 or G5.5, you can step up to all the great features of RealFlight 6 — with one easy-to-install DVD!  
 GPMZ4468 RealFlight 6 Upgrade

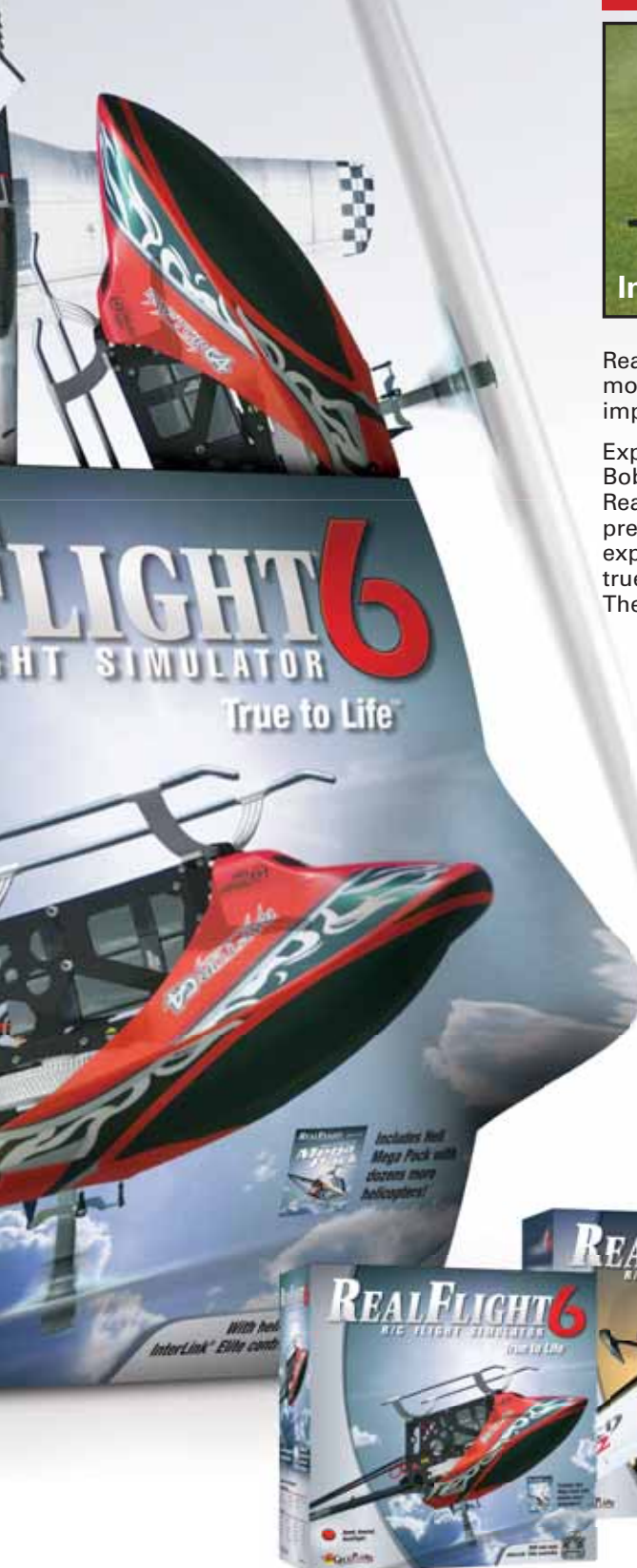

# IT'S TIME FOR GET OUT. GET DIRTY.™



# It's a change GET DURATRAX.

It's a new day.  
It's a new attitude.  
It's A NEW DURATRAX.



1989



1999



2011

Back in the late 80's Duratrax was just a tire line, offering quality and durability in a wide variety of tread designs. Several years later the company began making more car accessories, along with manufacturing affordable vehicles that sport modelers could bash around and have fun with. But that was then.

This is now. This is Duratrax with a decidedly aggressive new way of looking at R/C. With advancements such as Futaba® 2.4GHz FHSS radio compatibility, waterproof electronics and MagnaFlex™ components. With licensed scale vehicles that faithfully replicate full-size racers and off-roaders. While retaining the same reliability and parts support that Duratrax has always been known for.

*It's time to get outside and mix it up. To experience R/C like you never have before. It's time to... **Get Out. Get Dirty. Get Duratrax***



# VW BAJA BUG

1/10 Scale EP 2WD RTR

## *The Blast from the Past!*

The VW Bug is no toy; it's the genuine off-road article, with a licensed VW Baja body to prove it. It has more than the looks of champions of the past; it has the same survival skills, too. It takes harsh terrain in stride, takes sand dunes as easily as dirt roads — and can run in any weather condition. MagnaFlex™ components in critical areas provide the durability and strength to go the distance — and the Stress-Tech™ FREE Replacement Guarantee backs up the performance promise with a full year of real protection.

It's ready-to-run — and ready to go beyond where the sidewalk ends.



DTXD36\*\* VW Baja Bug 1/10 2WD EP 2.4GHz RTR  
DTXD36BWVW Baja Bug 1/10 2WD EP 2.4GHz RTR-Blue/White  
DTXD36RR VW Baja Bug 1/10 2WD EP 2.4GHz RTR-Red  
DTXD36WL VW Baja Bug 1/10 2WD EP 2.4GHz RTR-White/Black  
DTXD36YYVW Baja Bug 1/10 2WD EP 2.4GHz RTR-Yellow

**Length:** 18.2 in (465 mm)  
**Width:** 9.5 in (240 mm)  
**Height:** 8.7 in (220 mm)  
**Weight:** 3 lb (1.36 kg)

Officially licensed  
by Volkswagen





Battery shown is not included.



2.4GHz radio system

- Duratrax 2.4GHz FHSS radio system by Futaba®
- Sprint™ 2 Plus ESC with LiPo cutoff
- Photon Speed™ 2 19T modified motor
- Painted, finished polycarbonate body
- Assembled, oil-filled shocks
- MagnaFlex™ plastic components



# THE FIRST REAL INNOVATION



WE ARE RADIO CONTROL

MORE METAL  
MORE INNOVATION  
MORE DURABILITY  
VALUE PRICED

## ARRMA will blow you away!

ARRMA may be new to the R/C market, but their management and design teams have decades of experience in the industry. Combine that with an aggressive approach to research and development and state-of-the-art manufacturing facilities, and you've got an exciting new brand of R/C models that you're gonna want to go with — and go FAST!



**Quick-Change Batteries**  
*No need to remove the body*

## Here's why you'll want to own ARRMA:

- The finest quality materials — all rigorously tested and approved
- Exciting original and scale designs — covering virtually every style of R/C car and truck, with many more in the works
- A streamlined, "modular" chassis — where every ARRMA model shares many key features
- Extensive parts compatibility (47%) — to keep aftermarket support simple
- A total commitment to keeping costs down — to provide models that are great fun while also being an excellent value
- A pledge to provide rapid product delivery and ongoing customer support
- An iron-clad 2-year warranty — unlike any other manufacturer's warranty in the industry

**Aluminum TVP Chassis Rails**



## Standard on all ARRMA vehicles



# IN RC CARS IN 5 YEARS



Complete line-up coming

**RAIDER**

Raider  
Off-Road Buggy



DUE OCT

**ADX-10**

ADX-10  
Race Buggy



DUE JAN

**FURY**

Fury  
Short Course Truck



DUE NOV

**GRANITE**

Granite  
Monster Truck



DUE DEC

**VORTEX**

Vortex  
Stadium Truck



DUE DEC

**MOJAVE**

Mojave  
Desert Truck



DUE JAN

Want an example of ARRMA innovation?  
Check out the adaptable transmitter!

With the press of a button, the ATX300 transmitter can be switched from left-handed to right-handed and back again. It allows anyone to hold the radio in the way that feels most comfortable — and only ARRMA offers it!  
Design Patent No. 29/384,679



[www.arrma-rc.com](http://www.arrma-rc.com)

# THE FIRST RELEASE FROM ARRMA



[www.arrma-rc.com](http://www.arrma-rc.com)

Looks, durability, performance, value...it's all here with ARRMA!

- Fully independent suspension
- Oil-filled gear diff and shocks
- Aluminum TVP (Twin Vertical Plates) chassis and alloy front chassis plate
- Pre-glued all-terrain dBots 'Dunerunner' tires with foam inserts and chrome spoked wheels
- Tough steel turnbuckles, driveshafts and axles
- Brushless-ready all-metal transmission components
- Factory-printed polycarbonate body with a WOW! factor trim scheme
- Molded rear wing
- Powered by a MEGA 15T brushed motor with waterproof ESC
- ATX300 2.4GHz radio with
  - 6-model memory
  - AS-1 steering servo
  - Steering Dual Rate
  - End Point Adjustments
  - Fail Safe
  - Steering and Throttle trim and servo reversing
  - 3rd channel button

ARAC2011 Raider 1/10 Scale 2WD Baja Buggy RTR 2.4GHz-Yellow  
 ARAC2021 Raider 1/10 Scale 2WD Baja Buggy RTR 2.4GHz-Green  
 ARAC2031 Raider 1/10 Scale 2WD Baja Buggy RTR 2.4GHz-Red  
**Length:** 15.75 in (400 mm)  
**Width:** 9.9 in (252 mm)  
**Height:** 5.5 in (140 mm)  
**Weight:** 3 lb (1360 g)  
**Requires:** 7.2V NiMH battery, charger, 4 "AA" batteries for the transmitter



NEW PRODUCT

# CUTTING-EDGE CONTROL FOR THE CLASSIC CESSNA!

www.gpdealer.com



## Cessna® 182 SKYLANE®

Now with  
**TACTIC™**  
2.4GHz

Select Scale™ **RTF™**  
READY-TO-FLY

The 6-channel Tactic 2.4GHz radio is top-of-the-line technology! It also features dual rates, digital trims and a wireless trainer system

### Performance Pluses:

- Brushless motor and ESC
- 11.1V 1800mAh balanced LiPo battery
- Working drop-hinged flaps
- Steerable nosewheel with working shock
- AC/DC balancing charger

### Appearance Extras:

- Installed, 7-LED lighting system
- Corrugated control surfaces
- Tinted windows
- Factory-applied, Cessna-style trim scheme

HCAA2524 Select Scale Cessna 182 Skylane EP RTF

Wingspan: 47.5 in (1205 mm)

Length: 39 in (990 mm)

Weight: 37 oz (1050 g)

# Flyzone™

Cessna 182, Skylane, emblems, logos and body designs are trademarks of Textron Innovations, Inc. and are used under license by Hobbico, Inc.

### **From the Experts:**

Select Scale doesn't just mean more detail — it also means superior performance, and that's where this Cessna with a Tactic 2.4GHz radio really shines! In the air the Skylane is stable enough at low throttle for first-timers; with full throttle it boasts all the agility and brushless power an accomplished pilot could want!

### **Long story short...**

**With scale appearance, brushless performance, RTF convenience AND a 2.4GHz radio, the Flyzone Select Scale Cessna 182 Skylane has it all!**



# YOUR NEXT GREAT FLYING

www.gpdealer.com



The lightweight, high-quality fiberglass fuse includes an easy-access hatch for installing a 3-cell, 11.1V on-board battery. Its magnetically secured cover allows quick flight pack changes.

Pilot figure shown not included.

- Delivers strong flight performance, including basic aerobatics, while offering unique flying site options
- Fuselage hull includes strakes and optimized step placement for smooth, predictable takeoffs and easy handling on the water
- Features a painted fiberglass hull and built-up, MonoKote®-covered wing and tail
- Comes with hinged ailerons, painted and trimmed nacelles and floats, and installed clear windows

ADVENTURE

*G-44 Widgeon*

GPMA1151 G-44 Widgeon EP Seaplane ARF

Wingspan: 51 in (1295 mm)

Length: 36 in (915 mm)

Weight: 4-4.5 lb (1810-2040 g)

**ElectriFly**<sup>®</sup>***From the Experts:***

From small ponds to large lakes, virtually any outdoor body of water can become a runway for the G-44 Widgeon ARF. It taxis easily, takes off with authority, and excels with brushless electric power. You'll enjoy its smooth sport performance just as much as you'll admire its scale details when it's on display.

***Long story short...***

***When you're ready to explore new sport flying frontiers, think water — and the ElectriFly G-44 Widgeon seaplane!***



# BECOME THE BARON



- 100% complete — ready for flight in minutes
- Includes a Tactic™ 2.4GHz micro radio, designed for a comfortable grip and smooth, fast response
- Enjoy up to 10 minutes of air time per charge — and recharge on the radio!
- Arrives finished in authentic Axis colors and trim

# OF YOUR BACKYARD!

## fokker Dr.1

Everything is included — nothing left to buy!



Includes:

- Assembled Fokker Dr.1 with pilot\*, machine gun\*, replica radial engine and WWII trim scheme
- Tactic 2.4GHz micro radio with built-in charger
- Rechargeable 3.7V 130mAh LiPo flight battery
- Five "AA" radio batteries

\*Requires installation. Pilot also requires painting.

HCAA2554 Fokker Dr.1 Micro EP RTF

Wingspan: 14.1 in (360 mm)

Length: 12 in (305 mm)

Weight: 1.27 oz (36 g)

**Flyzone**™

### ***From the Experts:***

With the Fokker Dr.1, deciding where to fly it might be the most difficult thing about it. Its compact (14.1") wingspan lets you take it almost anywhere, from your backyard to inside the school gym. There's very little assembly, and absolutely nothing left to buy. Just charge the battery pack and you're ready for flying fun!

### ***Long story short...***

***In no time you can have the Fokker Dr.1 in the air and flying sorties almost anywhere indoors or out!***



# THE LEGENDARY RACER OF THE

www.gpdealer.com



The cockpit windshield doubles as a “hidden” battery hatch for convenience. Magnets on the fuselage and hatch hold tight in flight, but release cleanly for fast, easy pack changes.

- Captures the original’s classic looks in a design created for cutting-edge brushless power and easy assembly
- Spans 52”, for easy handling in light winds and easy transportation without teardown
- Reproduces the clean, uncluttered silhouette with an all-wood airframe, MonoKote® film and painted fiberglass parts
- Includes prehinged flaps, ailerons and elevators, a cowl with molded-in blister detail and a replica radial engine complete with pushrod detail

Pilot figure not included.

30'S RETURNS!

# 'MISTER' MULLIGAN

Almost Ready-to-Fly Electric Sport-Scale Airplane



**MONOKOTE**  
COVERING

### ***From the Experts:***

It remains the only plane ever to have won the coveted Bendix and Thompson trophies in the same year. Now the Howard DGA-6 — also known as “Mr. Mulligan” — returns as a quality-built ElectriFly ARF that both sport pilots and scale enthusiasts will want to own. With its ease of assembly, attention to detail and spot-on performance, the Mr. Mulligan is a great way to relive the golden age of air racing!

### ***Long story short...***

***With the Mr. Mulligan you can experience the thrill of piloting a cross-country winner and pylon racing star!***

**GPMA1485 Mr. Mulligan EP ARF**  
**Wingspan:** 52.5 in (1335 mm)  
**Length:** 41.5 in (1055 mm)  
**Weight:** 5.25-5.75 lb (2380-2610 g)

**ElectriFly®**



NEW PRODUCT

A NEW TAKE ON 3D FOAMIES!

# CITABRIA

www.gpdealer.com



**PRO-FORMANCE FOAM**™

- Made from Pro-Formance™ foam, an ElectriFly exclusive — and the best choice for feather-light, arrow-straight and super-strong airframes
- Flight surfaces are prehinged with genuine 3M® Blendederm® tape; carbon-fiber parts and laser-cut hardware help minimize assembly
- A stunning, high-visibility trim scheme makes it easy to follow in flight

3M® and Blendederm® are registered trademarks of the Minnesota Mining and Manufacturing Company.





The Citabria flies impressively when you add a RimFire™ 250 outrunner brushless motor and an 8x3.5 PowerFlow™ 3D prop. Motor not included.

## ElectriFly®

GPMA1127 Citabria 3D Foam EP ARF  
 Wingspan: 33 in (840 mm)  
 Length: 29.5 in (750 mm)  
 Weight Range: 6-6.3 oz (170-180 g)

### ***From the Experts:***

The Citabria 3D takes a fresh look at foam flyers, with a new shape that's like no other. The high wing design and vibrant trim scheme make it really stand out from all the Extras and Yaks out there, and it's easy to assemble and affordable to equip. It's an ideal change-of-pace airplane for the 3D enthusiast!

### ***Long story short...***

***Show off your wild side – both indoors and out – with the Citabria 3D!***



# AXIAL 1/10 WRAITH™ 4WD

The "go fast, go everywhere" Wraith™ Rock Racer — in kit form!

www.gpdealer.com

- Universal joint axles
- Threaded aluminum lower links
- AR60 OCP-Axle™ (Off-Center Pumpkin design)
- Corbeau® LG1 Racing Seats
- Easy-access differential



- Constant Velocity Joint Design (CVJ)
- Full Metal-To-Metal Construction for the CVJ-Housing
- Friction Free Movement / Smooth Articulation
- Metal Ring Protection & Capture for the CVJ-Pin
- "Tough-as-Tusk" Durability
- Easy Assembly & Maintenance

# ROCK RACER KIT



The 2.2 Ripsaw™ tires offer realistic looks for the image-conscious scaler, while the aggressive tread design and R35 compound offer superior gripping performance. Officially licensed 2.2 Raceline Renegade wheels add even more authenticity, and will stand up to rugged off-road action.



A full-tube composite injection molded frame chassis keeps everything protected. Tuned shock springs provide the right balance for reaching high speeds and handling harsh terrain.

## AXID9020 1/10 Wraith™ 4WD Rock Racer Kit

**Length:** 19 in (483 mm)

**Width:** 11.6 in (295 mm)

**Height:** 9 in (229 mm)

**Wheelbase:** 13.5 in (343 mm)

**Ground Clearance:** 3 in (76 mm)

**Weight (w/o electronics):** 4.9 lb (2.22 kg)



## *Long story short...*

*From off-road bashing to treacherous rock crawling to serious sport racing, the 1/10 scale Wraith™ 4WD Kit does it all!*



NEW PRODUCT

# HPI 1/8 VORZA FLUX HP

The record-setting Vorza Flux HP gets a make-over!

www.gpdealer.com



HB/HPI Proto tires



Insane speeds  
of up to **73** mph!\*

\*with optional gearing, tires and (2) 6S 11.1V LiPo packs.

Catch big air with hair-raising BMX jumps, or capture the checkered flag in top-level racing action! The 1/8 Vorza Flux HP is fully capable of both, thanks to overall upgrades from the crack team of HPI engineers. Using the World Champion HB D8 buggy as its foundation, the Vorza Flux HP utilizes the best in brushless technology to take on the competition and come out on top!

- All the top-of-the-line features you could want, AND it's Ready to Run!
- Equal-length 16 mm HB Big Bore shocks smooth out the ride and provide plenty of adjustability
- The drivetrain is rock-solid reliable, with D8 spiral-cut worm gear diffs that transfer the most power from the driveshafts to the wheels
- Comfortable, interference-free control is yours with the included 2.4GHz radio system — and no crystals to contend with!

# BRUSHLESS 2.4GHz RTR

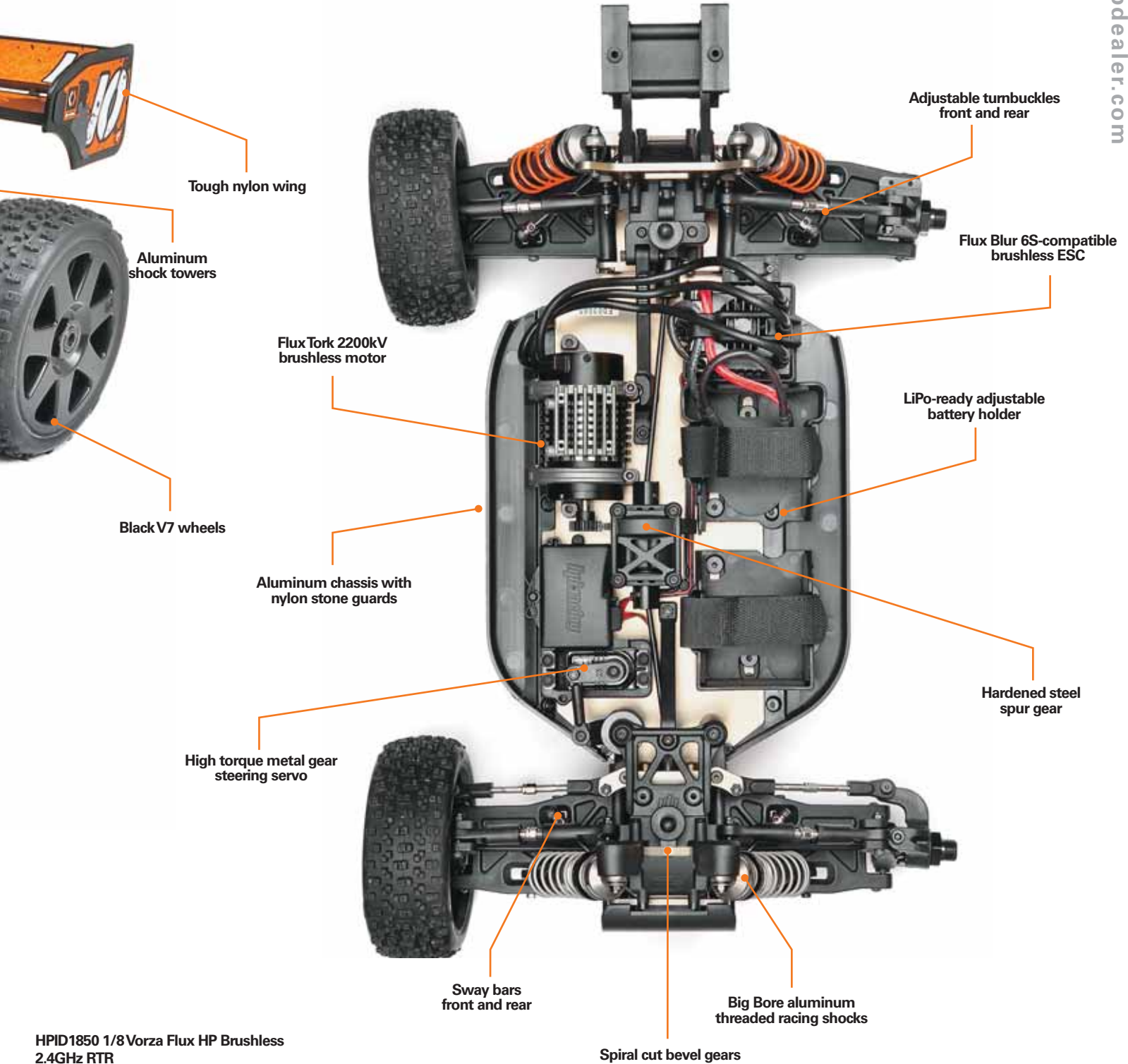

**HPID1850 1/8 Vorza Flux HP Brushless  
2.4GHz RTR**  
**Length:** 20 in (508 mm)  
**Width:** 12 in (205 mm)  
**Height:** 7 in (178 mm)  
**Wheelbase:** 12.8 in (325 mm)



## Long story short...

*Just when you thought a World Championship-level buggy couldn't get better...along comes the Vorza Flux HP with even more cutting-edge upgrades!*



# TWO WAYS TO FLY ANYWHERE — IN A SNAP!

## Überlites™

www.gpdealer.com



### Truly "fly anywhere" models that anyone can afford and enjoy!

- At just over a half an ounce, Überlites are among the lightest R/C planes ever engineered
- The innovative "Snap & Fly™" system utilizes an interchangeable flight module that powers and controls all Überlite aircraft
- Each Überlite set comes with 2 airframes (a biplane and monoplane), one flight module, a 2.4GHz radio with charger, a LiPo flight battery and 4 "AA" radio batteries

### It's as easy as 1-2-3:

- 1 SNAP on the flight module — until it magnetically clips into place!
- 2 CHARGE the battery — right from the transmitter's USB style port!
- 3 FLY indoors or out — virtually any room can become a flying field!

HCAA2560 Überlites 2-in-1 Monoplane/Biplane RTF Set  
**Monoplane**  
 Wingspan: 16.1 in (410 mm)  
**Biplane**  
 Wingspan: 14 in (355 mm)

Also available: a separate Wing airframe that can be flown using equipment included with the 2-in-1 set!



HCAA6395 Überlite Wing Airframe  
 Wingspan: 9.5 in (240 mm)  
 Weight: 0.6 oz (17 g)  
 Flight module and radio not included

**ItCanFly®**  
 Modular Aircraft

**Flyzone™**

### From the Experts:

There's nothing else in R/C quite like Überlites! These feather-light flyers come fully assembled, and are powered by a module that holds all the electronics for flying anywhere indoors (or outside on a very calm day). Each set includes two airframes, one flight module, a 2.4GHz radio and all batteries. Überlites are easy enough for any modeler to start piloting right out of the box.

### Long story short...

Enjoy real, affordable R/C flight virtually anywhere with the complete, ready-to-fly Überlite 2-in-1 Set!

# NEW HIGH-VOLTAGE SERVOS FROM FUTABA®

S9352HV & S9353HV  
High Voltage HT/HS Servos



- Superb all-around, multi-application servos!
- Both can be used in 1/8 scale truggies, buggies and crawlers, as well as airplanes and helis
- Equipped with dual bearings and super-tough titanium gears, and both are water protected
- S9352HV has a metal center case, while S9353HV features a full metal case for added durability

FUTM0720 S9352HV High Voltage HT HS MCC Servo  
FUTM0721 S9353HV High Voltage HT HS FMC Servo

Specifications for both:  
74v 2S Lithium battery  
Torque: 306 oz-in (22.0 kg/cm)  
Speed: 0.06 sec/60°



BLS256HV  
High Voltage  
High Speed Servo



- A great performance boost for heli tail rotor!
- In addition to brushless operation it comes with dual bearings, metal gears, metal center case and is water protected

FUTM0759 BLS256HV High Voltage HS MCC Servo

Specifications:  
74v 2S Lithium battery  
Torque: 70 oz-in (5.0 kg/cm)  
Speed : 0.05 sec/60°

## Long story short...

*Futaba High Voltage Servos are designed to handle the increased power load of LiPo cells!*

# CASTLE™ CREATIONS MAMBA MAX RACE PRO SCT 25.2V 3800KV SYSTEM

The ideal combo of power and speed.



Available only at Great Planes®!

- Offers extreme performance for short course trucks and CORR vehicles up to 6.5 lbs!
- The Neu-Castle 4-pole 1410 3800kV motor features a 40% longer rotor and stack than those in the CM36 series
- This motor pairs up perfectly with the Mamba Max Pro SCT ESC with SmartSense™ that utilizes the best of both sensed and sensorless technology
- A CC blower fan shroud is included that helps the motor run cooler

## Long story short...

*More power to you – thanks to the wallop you get from Castle's Max Race Pro SCT 25.2V 3800kV system!*

CSEC9600  
Max Race Pro SCT 25.2V 3800kV System



## Associated Reedy WolfPack LiPo Packs

*Meets the performance demands of sport drivers and club racers!*

- Both packs feature high-quality cell manufacturing inside a molded hard case for maximum crash protection
- Instead of power-robbing "universal" plugs, WolfPack LiPos come equipped with beefy silicone wires and a low-resistance Deans® Ultra Plug® connector
- Generous discharge capabilities increase overall power and top speeds; high capacities extend run times far beyond NiMH packs or lower-quality LiPos

Deans® and Ultra Plug® are registered trademarks of W.S. Deans Co. U.S. Patent No. 5,533,915



**ASCC0734**  
Reedy WolfPack 7.4V  
6500mAh 25C LiPo Pack



**ASCC0735**  
Reedy WolfPack 11.1V  
3900mAh 35C LiPo Pack

## Tekin® T-Series HD Rock Crawler Brushed Motors

*Designed to get you where you want to go — with authority!*

- Features an upgraded high-strength ferrite magnet
- Completely rebuildable
- Dual precision ball bearings
- Available in 35, 45 and 55 turn options

TEKC2113 T-Series HD Rock Crawler Brushed Motor 55T  
TEKC2114 T-Series HD Rock Crawler Brushed Motor 45T  
TEKC2115 T-Series HD Rock Crawler Brushed Motor 35T



**TEKC2113**  
T-Series HD Rock Crawler  
Brushed Motor 55T

## TrakPower™ 2S 7.4V 5400mAh 60C LiPo Saddle Pack

*A ROAR-sanctioned powerhouse for 1/10 scale racers!*

- Pure power for blistering speeds, and high capacity for longer run times
- A hard case offers protection from the elements and crash damage
- Comes equipped with female bullet connectors



**TKPC0420**  
2S 7.4V 5400mAh  
60C LiPo Saddle Pack

## TrakPower™ Gear Grease & Silver Solder

*"Must-haves" for the serious modeler!*

- Use Gear Grease for superior lubrication to reduce friction and wear for gears, universals, thrust bearings and other applications
- Waterproof, with specially formulated "non-sling" properties
- Rosin Core Silver Solder provides strong solder joints with low resistance and high conductivity
- Environmentally safe, containing no lead and 3% silver content



**TKPC8008**  
Gear Grease



**TKPR0975**  
Silver Solder

# A 2ND FASST RECEIVER IS YOURS FREE... IF YOU ACT NOW!



A \$119.99  
retail value!

A \$124.99  
retail value!

# Futaba®



## Get a 2nd 2.4GHz receiver ABSOLUTELY FREE!

It's an offer as incredible as Futaba FASST systems themselves: buy a FASST 7C, 8FG Super, 10CG, 12FG, 12Z or 14MZ aircraft radio or 4PKS surface system before October 31, 2011, and you'll get a 2nd receiver AT NO EXTRA CHARGE — on the spot! You'll receive a 2nd R617FS receiver with an aircraft system, or a 2nd R603FS receiver when you buy a 4PKS radio.

There's no form to fill out, and nothing to send in. These receivers retail for as much as \$124.99 — making this an opportunity you can't afford to pass up!

The last day for this promotion is October 31, 2011!

## Get a FREE FASST receiver with any of these FASST systems!

FUTK7000	7CA (4)3152
FUTK7001	7CH (4)3152
FUTK7002	7CA (4)3004
FUTK7004	7CA Tx/Rx
FUTK7005	7CH Tx/Rx
FUTK8010	8FGA Super
FUTK8011	8FGH Super
FUTK9255	10CAG Air Mode 2
FUTK9256	10CHG Heli Mode 2
FUTK9257	10CAG Air Mode 1
FUTK9258	10CHG Heli Mode 1
FUTK9275	12FGA
FUTK9276	12FGH
FUTK9300	12ZAP
FUTK9301	12ZHP
FUTK9400	14ZAP
FUTK9401	14ZHP
FUTK4901	4PKS

Available only at participating hobby shops in the U.S. and Canada through October 31, 2011, or while supplies last. This is not a rebate offer and is not retroactive. You will receive your Free receiver at the point of sale. There are no substitutions.

# UP TO \$10 OFF ON LIFESOURCE BATTERY/CHARGER COMBOS!

Buy cutting-edge LiFeSource receiver batteries together with the convenient, easy-to-use LiFeSource AC/DC Balance charger and SAVE MONEY!



**\$5 OFF!**

LiFeSource AC/DC Balance Charger & 1100mAh Rx Battery Pack  
LiFeSource AC/DC Balance Charger & 1300mAh Rx Battery Pack

**\$8 OFF!**

LiFeSource AC/DC Balance Charger & 1800mAh Rx Battery Pack  
LiFeSource AC/DC Balance Charger & 2100mAh Rx Battery Pack

**\$10 OFF!**

LiFeSource AC/DC Balance Charger & 3200mAh Rx Battery Pack



**DON'T DELAY...THESE OFFERS EXPIRE OCTOBER 31, 2011!**

## THE POWER IS PRICELESS... THE GLOW PLUG CADDY IS FREE!



**12XZ  
Speed  
Spec**



**21VG**

### Get a FREE Glow Plug Caddy when you buy any of these engines:

- OSMG1986** 12TG-(P) ABL w/12D Slide Valve Carb
- OSMG1991** 12XZ Speed Spec II
- OSMG1993** 12XZ ABC w/12F Slide Valve Carb
- OSMG2034** 15CV-X ABL w/10E Rotary Carb
- OSMG2035** 19XZ-B Speed ABC w/21J2 Slide Valve Carb
- OSMG2041** 21XZ-R Speed ABC w/21M Slide Valve Carb
- OSMG2042** 21XZ-R VII On-Road
- OSMG2050** 21XZ-B ABC w/21J2 Slide Valve Carb
- OSMG2051** 21XZ-B Speed ABC w/21J2(B) Slide Valve Carb
- OSMG2057** 21VG(P) w/21F Carb
- OSMG2068** 21VZ-B V-Spec-T(P) w/21J Slide Valve Carb
- OSMG2071** 21VG(P) ES w/21F Carb
- OSMG2074** 28XZ(P) Truggy ABC w/21J Slide Valve Carb
- OSMG2076** 30VG(P) ABL w/21E Slide Valve Carb
- OSMG2078** 30VG(P) ES ABL w/21E Slide Valve Carb
- OSMG2080** 25XZ(P) Truggy ABC w/21J Slide Valve Carb
- OSMG2082** 21TM Revo Manifold ABC w/11K-R Slide Valve Carb
- OSMG2083** 21TM T-Maxx Manifold ABC w/11K Slide Valve Carb
- OSMG2102** 18CV-RX ABC w/11G Slide Valve Carb
- OSMG2104** 18CV-RX ABC w/11J Rotary Carb
- OSMG2105** 18CV-RX(S) ABC w/11J Rotary Carb
- OSMG2110** 18TZ(P)-T ABC w/11K Slide Valve Carb
- OSMG2113** 18TZ-TX ABC w/11L Rotary Carb



**Keeps glow plugs  
and other small parts  
protected and organized!**



# GET FREE TIRE GLUE ON TOP OF PERFORMANCE TIRES!



**FREE!**  
DTXR2002

**Buy any select pair of Performance Tires, and get a bottle of Pit Tech™ Tire Glue FREE — a \$4.99 retail value!**

- DTXC3710 X-Cons™ 1/8 Buggy Tire (2)
- DTXC3711 X-Cons 1/8 Buggy Tire C3 (2)
- DTXC3715 Lockup™ 1/8 Buggy Tire (2)
- DTXC3720 Lineup™ 1/8 Buggy Tire (2)
- DTXC3721 Lineup 1/8 Buggy Tire C3 (2)
- DTXC3725 Shotgun™ 1/8 Buggy Tire (2)
- DTXC3726 Shotgun 1/8 Buggy Tire C3 (2)
- DTXC3730 Posse™ 1/8 Buggy Tire (2)
- DTXC3731 Posse 1/8 Buggy Tire C3 (2)
- DTXC3735 Deringer™ 1/8 Buggy Tire (2)
- DTXC3740 Spurz™ 1/8 Buggy Tire (2)



Lockup Buggy Tires  
DTXC3715



Posse Buggy Tires  
DTXC3730



Spurz Buggy Tires  
DTXC3740

Forms a lasting bond between wheels and rubber tires — don't leave the pits without it!

**DON'T DELAY... THESE OFFERS EXPIRE OCTOBER 31, 2011!**

## ENJOY CONVENIENCE AND PERFORMANCE... WHILE SAVING \$\$\$\$!

**When you purchase the Trak Pak Clean & Lube Combo, you pay only for the Speed Wash™ and Speed Prep™ — the KryTech™ Dry Wax Lube is FREE!**

For a limited time you can get TrakPower Speed Wash, Speed Prep and KryTech Lube together in one convenient package... for the price of just the Speed Wash and Speed Prep. That's a savings of \$7.99\*!

These quality TrakPower products are already a big hit with hobbyists, with lots of applications around the home as well. And now they're also a terrific value when you buy the all-in-one Trak Pak Clean & Lube Combo!

\*KryTech Lube retail price.



TKPC8010

# GET A PREMIUM PLUG WHEN YOU BUY AN AWESOME AX ENGINE!



OSMG2713

A \$9.99 retail value!

It's the ideal accessory that every airplane modeler needs!

Buy any of these engines and get a FREE #7 glow plug!

- OSMG0527** 25AX ABL w/21K E3080
- OSMG0545** 35AX w/E-3080
- OSMG0547** 46AX ABL w/Muffler
- OSMG0556** 55AX ABL w/Muffler
- OSMG0558** 65AX ABL w/4010A
- OSMG0575** 75AX ABL w/Muffler
- OSMG0580** 95AX Ringed w/61C E4040
- OSMG0650** 1.20AX Ringed w/Muffler
- OSMG0651** 1.20AX Ringed w/o Muffler



46AX



95AX



HURRY THESE OFFERS END OCTOBER 31, 2011!

## A TITAN X50 HELI + O.S. 55HZ-R ENGINE + FREE MERCHANDISE = YOU WIN!

Titan X50B Kit & 55HZ-R Engine



Titan X50 w/Torque Tube Tail & 55HZ-R Engine



When paired together the Titan X50 and the O.S. 55HZ-R engine create an extreme aerobatic machine — and through October 31, 2011 when you buy either the belt-driven or torque tube driven Titan X50 kit with the 55HZ-R engine, you'll receive a certificate worth up to \$100 towards quality R/C merchandise from nearly 30 top brands!

Go to [tamerica.com](http://tamerica.com) for official rules and the downloadable request form.

HURRY — THIS IS THE LAST MONTH TO TAKE ADVANTAGE OF THIS OFFER!



THUNDER TIGER®



Available only at participating hobby dealers in the U.S. and Canada. Rebates apply to purchases made between August 1 and October 31, 2011. Rebates are not distributed in stores. Rebate request forms and official rules are available at [tamerica.com](http://tamerica.com). All required materials to receive the merchandise certificate must be submitted by November 30, 2011.

# GET A FREE ELECTRIFLY® OR FLYZONE™ T-SHIRT!



www.gpdealer.com

**Last Month!**

If you've been thinking about purchasing a Receiver-Ready plane, NOW is the time! Through the end of October 2011 when you buy a quality ElectriFly or Flyzone Rx-R model you'll also receive a FREE T-shirt! Wear it proudly while enjoying the time-saving convenience and flexibility of your Rx-R. From slow, stable flyers to exhilarating EDF jets, there's a Receiver-Ready plane for every flying style.



A retail value of up to \$18.99!



Seawind™ Rx-R  
GPMA5750



F-20 Tigershark EDF Rx-R  
GPMA6010



Super Sportster™ Rx-R  
GPMA6006

- GPMA5750 Seawind™ Rx-R
- GPMA6000 Synapse™ Rx-R
- GPMA6006 Super Sportster™ Rx-R
- GPMA6004 FlyLite™ Rx-R
- GPMA6010 F-20 Tigershark EDF Rx-R
- GPMA7500 ElectroStik™ Rx-R

**ElectriFly®**

Don't delay...these offers end October 31, 2011!



Cessna® 182  
Skylane® Rx-R  
HCAA2525

Sensei™ Rx-R  
HCAA2536

Focke-Wulf Fw 190 Rx-R  
HCAA2539

- HCAA2525 Cessna® 182 Skylane® Rx-R
- HCAA2528 Super Cub Rx-R
- HCAA2534 Cessna 350 Corvalis® Rx-R
- HCAA2536 Sensei™ Rx-R
- HCAA2539 Focke-Wulf Fw 190 Rx-R

**Flyzone™**



A retail value of up to \$13.99!

Void where prohibited. Some terms, conditions and restrictions apply, and only while supplies last. Available at participating local hobby shops only. Go to [electrifly.com](http://electrifly.com) or [flyzoneplanes.com](http://flyzoneplanes.com) for official rules and the downloadable request form.

## FEATURED MANUFACTURER

SC10RS SHORT COURSE RACE  
SPEC 2WD BRUSHLESS RTR

The SC10RS RTR is an exciting R/C replica of the trucks driven in the Lucas Oil Off Road Racing Series, and winner of the 2009, 2010, and 2011 ROAR Short Course National Championships. But Team Associated didn't rest on its laurels; instead, the SC10RS (Race Spec) RTR received major upgrades to make it even more competitive. And when you trick it out with recommended Reedy and Factory Team accessories, you'll have a truck that's equipped to dominate anywhere you want to race!

- Now featuring a powerful, water-resistant XP SC700 brushless speed control
- The 2.6:1 ratio gearbox includes a sealed gear diff with heavy-duty internal gears and externally adjustable V2 slipper clutch
- KMC® replica hex-drive wheels are mounted on high-traction JConcepts racing compound rear tires for better grip
- The suspension boasts adjustable blue-anodized V2 coil-over shocks
- An XP3-SS 2.4GHz 3-channel radio with metal gear steering servo offers dependable control
- Powered by a Reedy 3300kV brushless motor

Official R/C Car of the



ASCC7047 SC10RS Short Course Race Spec 2WD Brushless RTR-Monster Energy  
 ASCC7048 SC10RS Short Course Race Spec 2WD Brushless RTR-Pro Comp  
 ASCC7049 SC10RS Short Course Race Spec 2WD Brushless RTR-Rockstar/Makita  
 ASCC7050 SC10RS Short Course Race Spec 2WD Brushless RTR-Lucas Oil  
 Length: 21.6 in (550 mm)  
 Width: 11.5 in (293 mm)  
 Wheelbase: 12.9 in (327 mm)  
 Weight: 4.5 lb (2080 g)



# THE BEST TRUCK DESERVES THE BEST ACCESSORIES!

With Reedy and FactoryTeam hop-ups and equipment, you've got lots of options for perfectly adapting your SC10RS to track conditions and driving styles. Whether you're a seasoned R/C race veteran or a weekend warrior out for a good time in the dirt, Associated has you covered for batteries, chargers, motors, tools, fluids and ESCs. These are just a few of the items from Reedy and FactoryTeam to help you get your SC10RS totally dialed in!

## Reedy 526-S AC/DC 2S-6S Cell LiPo/LiFe Balance Charger

- The one-stop charging solution for electric racers wanting the flexibility to charge a variety of LiPo batteries.

ASCP0604



## Reedy Wolfpack 7.4V 35C 3400mAh LiPo Battery

- Generous discharge capabilities increase overall power and top speeds
- High capacities extend run times far beyond NiMH cells and low-quality LiPos

ASCC0732



## FactoryTeam 8-Piece 1/4" Hex Driver Set

- All of the most popular standard and metric hex sizes, conveniently stored inside the machined aluminum handle
- The hardened tips can be used with power drivers for tackling heavier jobs

ASCR1655

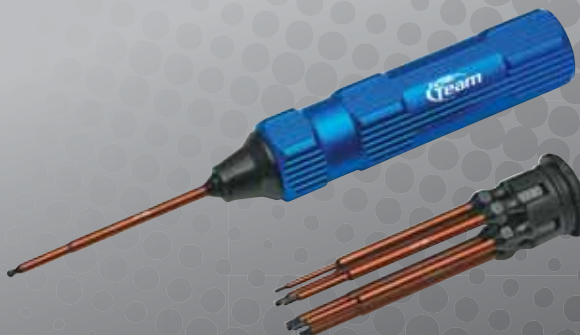

TURN HERE FOR GENERAL HOBBY PRODUCTS





### 1/24 SCALE '78 PONTIAC® FIREBIRD® 3 'N 1

The Bandit's high-octane ride.

With its distinctive black paint scheme and gold accents, the 1978 Pontiac Firebird is one of the 1970s' signature muscle cars. Pontiac boosted power by 10% compared to previous models, resulting in a whopping 220 hp rating. The car's appearance in 1977's "Smokey and the Bandit" contributed to its best-selling status. **Kit features** the choice between building a street machine, dragster or stock Firebird. Also features two highly detailed engine set-ups, soft black tires, chrome-plated parts, two wheel options and decals for street stock, street machine and competition versions.

RMXS4927 Total parts: 106 Skill level 2 Length: 8.3 in (210 mm)



### 1/24 SCALE '40 FORD® CUSTOM PICKUP TRUCK

America's love of Ford hot rods lives on.

The classic '40 Ford pickup is as popular with car collectors today as it was with the public during its original release. One reason the '40 is still a favorite is its characteristic V-shaped grille. This unique feature has made it a choice for custom-builders all over the world! **Kit features** a louvered hood, a detailed V-8 flathead engine with three carburetors and finned cylinder heads, a diamond-pleated interior, simulated wood bed rails, soft black tires, custom wheels, chrome-plated parts and decals with custom graphics.

RMXS4928 Total parts: 104 Skill level 2 Length: 7.7 in (195 mm)



### 1/24 SCALE STEVE KINSER #11 BASS PRO SHOPS® SPRINT CAR

Sprint car racing's biggest star.

American sprint car racing ranks among the world's fastest auto competitions. The most popular version of this sport uses winged cars for increased downforce and improved control. Sprint cars can reach speeds exceeding 140 mph (230 km/h), which is why roll cages, helmets and other safety features have been deemed mandatory by most divisions. **Kit features** a detailed V-8 racing engine, modern sprint car bodywork with a hood scoop and side panels, soft black tires, satin chrome-plated parts, a seated driver figure and decals with authentic 2011 Steve Kinser graphics.

RMXS4942 Total parts: 97 Skill level 3 Length: 6.3 in (159 mm)



### 1/25 SCALE '56 CHEVY® NOMAD® 2 'N 1

The true traveler's choice.

Like many Chevys that year, the '56 Nomad had many design changes. Instead of recycling the '55's front end (which looked like a Ferrari®), Chevy modified the '56 to include a full-width grille. A powerful V-8 engine helped make the Nomad a favorite of drivers everywhere. Today, the '56 Nomad remains a popular attraction at auto shows all over the country! **Kit features** a highly detailed chassis, a detailed V-8 engine, a realistic interior, soft black tires, chrome-plated parts, optional large-diameter custom wheels, stock wheels and California-style custom graphic decals.

RMXS4947 Total parts: 155 Skill level 2 Length: 8.1 in (205 mm)





**1/48 SCALE SB2C-4 HELLDIVER**  
The U.S. Navy's "Big-Tailed Beast."

In late 1943, the first SB2C Helldivers sailed for the Pacific aboard the U.S.S. Bunker Hill. Soon, they were participating in every major naval action in the Pacific. After WWII's end, they continued to serve the U.S. Navy until 1949. **Kit features** a cockpit with pilot figure, an exposed weapons bay with bombs, a detailed rear gun area, photo-etched perforated dive brakes and decals for two versions: 1. SB2C-4, VB-84, U.S.S. Bunker Hill, Tokyo Raids, February 16-23, 1945 and 2. SB2C-4, Marine Squadron VMSB-224, Bombing Banshees, Mindanao, June 2, 1945.

RMXS5983    Total parts: 115    Skill level 3    Length: 9.5 in (241 mm)  
Wingspan: 12.9 in (327 mm)

**Revell** REVELL OF GERMANY® PLASTIC MODELS



**1/72 SCALE LEOPARD 2 A6/A6M**  
Top-of-the-line, and updated for the 21st century.

Since its 1979 introduction, the Leopard 2 has evolved into one of the world's best tanks. The latest version (the A6M) offers improved anti-mine protection and a longer L55 gun. Germany, Afghanistan and Canada are just three (out of 17) countries that operate the Leopard 2. **Kit features** new tooling, a choice of original A6 or updated A6M models, finely detailed surface structures with non-slip coating, a rotating turret with opening hatches, an elevating gun, 12 smoke grenade dischargers, bendable two-part track pieces and decal marking options for 4 variants.

RVLS3180    Total parts: 168    Skill level 4    Length: 6 in (152 mm)



**1/72 SCALE DASSAULT®/DORNIER® ALPHA JET E**  
France's celebrated jet trainer.

Prized for its maneuverability, safety and first-class performance, the Alpha Jet has been used by the French Air Force since 1979. Initially developed as an advanced trainer and light combat/tactical support aircraft, the Alpha Jet recorded its one-millionth flying hour in 2008. To celebrate the occasion, one special aircraft was decorated with the "Alpha" logo and the Training Squadron's "AJeTS" insignia. **Kit features** textured surfaces, a detailed undercarriage, a cockpit with instrument panel, a separate landing light, optional wing fuel tanks, and a decal set with French Air Force livery.

RVLS3995    Total parts: 60    Skill level 3    Length: 6.6 in (167 mm)  
Wingspan: 5 in (128 mm)



**1/48 SCALE MESSERSCHMITT BF 109F-2/4**  
Ace-approved for WWII dogfighting.

Hans Joachim Marseille ranks among the most-decorated Luftwaffe aces of the WWII era. His flying skills were so highly regarded that Germans nicknamed him the "Star of Africa." While stationed in North Africa, Marseille scored 151 "kills," or 95 percent of his overall victories. **Kit features** a detailed DB 601 engine, two engine-mounted machine guns, a detailed cockpit with instrument panel, an optional tropical intake filter, a detailed undercarriage, a multi-part cockpit canopy, a moving propeller and decals for two Luftwaffe aircraft: 1. J. Marseille and 2. III/JG2.

RVLS4656    Total parts: 98    Skill level 4    Length: 7.5 in (190 mm)  
Wingspan: 8.1 in (206 mm)



### 1/48 SCALE SPAD XIII (LATE VERSION)

France's fearless fighter biplane.

By the autumn of 1917, the SPAD XIII was used in ever-increasing numbers by the French Air Force's fighter units. For the remainder of WWI, this fearless fighter biplane proved to be a worthy adversary when it was put in the hands of experienced pilots. **Kit features** finely textured and detailed surfaces, a detailed cockpit with control column and cable runs, two machine guns, a detailed undercarriage, a finely detailed nose and grille, three windshields, finely worked wing support struts and a choice of two different rotating propellers.

RVLS4657    Total parts: 86    Skill level 4    Length: 5.2 in (132 mm)  
Wingspan: 6.7 in (169 mm)



### 1/72 SCALE GLOSTER METEOR MK.4

The RAF's first jet-powered fighter.

Capable of speeds approaching 585 mph (941 km/h), the Gloster Meteor was the Allies' first operational jet in WWII. While it wasn't as aerodynamic as subsequent jets, the Meteor managed to outmaneuver its enemies with moderate success. No. 616 Squadron first received its Meteors in July 1944. By the following week, the squadron scored its first "kills" against two V-1 flying bombs. **Kit features** structured surfaces with engraved panel joints, a cockpit with instrument panel, a detailed undercarriage, fuel tanks, an alternate fuselage pod and decals for two RAF aircraft.

RVLS4658    Total parts: 76    Skill level 3    Length: 6.8 in (172 mm)  
Wingspan: 6.3 in (159 mm)



### 1/72 SCALE JUNKERS JU 88 A-4 BOMBER

Germany's dive-bombing dynamo.

Dive-bombing. Torpedo-bombing. Night fighting. The Junkers Ju 88 could do it all – and then some. One of the most-produced variants was the A-4, which offered more powerful engines, improved armor and extensive armament. Standard armament consisted of SC 250 and SC 500 bombs, which weighed approximately 3,310-4,410 lb (1,500-2,000 kg). Over 16,000 Ju 88s were produced from 1939 through 1945, but only two complete aircraft exist today. **Kit features** new tooling, naturally recessed panel lines, a detailed cockpit, an extensively equipped interior, plus separate control surfaces and landing flaps.

RVLS4672    Total parts: 140    Skill level 4    Length: 7.9 in (200 mm)  
Wingspan: 10.9 in (278 mm)



### 1/32 SCALE MIG-29 UB TWINSEATER

The Soviet Union's definitive fighter.

The MiG-29 UB is the two-seat trainer variant of one of the best multi-purpose combat aircraft to ever come out of the Soviet Union. In order to make space for the second pilot, this version lacks the pulse Doppler radar system found in the single-seat version. A positive thrust-to-weight ratio results in easy vertical takeoffs, and powerful dual Klimov RD-33 turbofan engines deliver an impressive top speed of Mach 2.3. **Kit features** exceptional filigree engraving, upgraded engine compartment detail and an extensive range of guided missiles and drop tanks.

RVLS4751    Skill level 3





### 1/350 SCALE GERMANY TYPE VIID U-BOAT

Specially designed, for laying mines.

It is hard to overestimate the role of minelayers in naval combat. The German Navy used these elongated U-boats to place mines near enemy shipping routes. The Type VIID featured five mine silos, located just behind the conning tower. Each silo could store up to three mines each, making the Type VIID a formidable foe for the Allies. **Kit features** an extended hull with fine riveting and welds, authentically reproduced deck details, a detailed engine, a realistic periscope, a true-to-the-original weapons assortment and decal markings for U-212, U-217 and U-218.

RVLS5107      Total parts: 28      Skill level 3      Length: 8.7 in (220 mm)



### 1/720 SCALE U.S.S. INTREPID (CV-11) 1944

The "Fighting I," in 1/720 scale.

Nicknamed the "Fighting I," the U.S.S. Intrepid was the third of twenty-four Essex-class carriers built for the U.S. Navy during WWII. She was crucial to several Pacific Theater campaigns, including the Battle of Leyte Gulf. After the war, she was used as a recovery ship during the Mercury and Gemini programs. Today, she is anchored off New York's coast as a museum ship. **Kit features** a textured flight deck, superstructures with radar equipment, a shipboard cannon, anti-aircraft guns, aircraft, four propellers and decal markings for the flight deck and aircraft.

RVLS5108      Total parts: 110      Skill level 3      Length: 14.5 in (369 mm)



### 1/250 SCALE SAILING SHIP PAMIR

The famous Flying P-Liner!

Prized for its speed and reliability, the four-masted Pamir was built in 1905 for the F. Laeisz Hamburg shipyard. She was the last wind-powered cargo ship to circle Cape Horn in 1949. While en route to Hamburg in 1957, the Pamir sank in a hurricane, with only six survivors. **Kit features** a detailed deck with planking, a textured two-part hull, detailed deck superstructures, detailed masts with yards, two anchors, six life boats, 34 textured sails, rigging thread, ready-made shrouds, ships' bell and rudder, rails, a display stand, decals and a flag table.

RVLS5629      Total parts: 268      Skill level 5      Length: 18.1 in (460 mm)  
Height: 10.1 in (256 mm)



### 1/1200 SCALE YAMATO

The IJN's tenacious WWII battlecruiser.

One of the largest, heaviest battleships ever constructed, the Yamato displaced a whopping 72,800 tons at full load. She was armed with nine 46 cm (18 in) main guns, which is the largest caliber artillery ever recorded for any warship. Surprisingly, the only time the Yamato ever fired her guns was during the Battle of Leyte Gulf in October 1944. Today, her legacy lives on at the Yamato Museum, which opened in 2005 to educate visitors about Japan's rich naval history. **Kit features** a waterline hull and anti-aircraft guns.

RVLS5813      Total parts: 33      Skill level 2      Length: 8.6 in (219 mm)



### 1/24 SCALE MERCEDES-BENZ® 540 K CABRIOLET A

Automotive perfection, 1930s-style.

Many automotive experts regard the Mercedes-Benz 540 K Cabriolet A to be the most perfect compressor-driven car of the 1930s. Its supercharged, 5.4L engine produced 180 hp, resulting in a top speed of 110 mph (170 km/h). The 540 K's luxurious design made it a hit with racers and royalty alike! **Kit features** a detailed chassis, a detailed 8-cylinder engine with chrome inlet pipes, a chrome radiator, a choice of building the car open or closed, a detailed interior and dashboard panel, separate white-band tires, chrome spoked rims and decals.

RVLS7001      Total parts: 111      Skill level 3      Length: 8.4 in (213 mm)



### 1/25 SCALE PORSCHE® CARRERA RS 3.0

Every speed demon's dream car.

The sleek, sporty Porsche Carrera RS 3.0 first rolled off the assembly lines in 1974. Power was provided by a K-Jetronic Bosch® fuel-injected engine, which produced an impressive 230 hp! **Kit features** a true-to-the-original chassis, a multi-part six-cylinder engine with a separate air filter, a multi-part Spartan interior with authentic dashboard, filigree shock absorbers and wheel suspension, a one-piece body, separate bumpers, a true-to-the-original rear spoiler, a separate hood, assorted chrome accent parts and decals with international markings (D, GB, F, NL, I, CH and B).

RVLS7004      Total parts: 84      Skill level 3      Length: 6.9 in (174 mm)



### 1/24 SCALE VW® GOLF GTI

The compact "Rabbit" returns!

Introduced in September of 1983, the second-generation Golf Mk2 combined the power of a sports car with the reliable features of an everyday transport. This 1980s **kit reissue features** a one-piece body with fine surface details, a detailed chassis with wheel suspension, a multi-part four-cylinder engine, an opening hood, a realistic interior with dashboard, an optional sunroof, a front grille with twin headlights and extensive decals with international markings (D, NL, F, CH, I, GB, S, A, DK and B).

RVLS7005      Total parts: 67      Skill level 3      Length: 6.6 in (167 mm)



### 1/24 SCALE AUDI® R8 SPYDER

Pure adrenaline, with V-10 engine power.

Unveiled by Audi in 2009, the R8 Spyder combines the unforgettable sound of a 5.2L V-10 mid-mounted engine with exceptional driving characteristics. Features include a "soft-top" roof and the removal of the sideblade found on other models. **Kit features** a body with fine surface details, an opening hood with a detailed V-10 mid-mounted engine, a separate exhaust system, detailed wheel suspensions, a detailed interior with dashboard and structured seats, an optionally open sunroof, turning wheels, chrome rims and decals with international registration marks (D, NL, F, I, B and GB).

RVLS7094      Total parts: 126      Skill level 3      Length: 7.3 in (185 mm)





**1/25 SCALE JAGUAR® XK-E**  
The artfully designed '60s icon.

Known as the E-Type in the United Kingdom, the Jaguar XK-E made its landmark debut at the Geneva Motor Show on March 15th, 1961. The XK-E was an instant success, and as the decade progressed, its iconic stature only increased over time. An estimated 70,000+ E-Type Jaguars were sold around the world between 1961 and 1975. One has even become a popular tourist attraction at New York's Museum of Modern Art®! **Kit features** a detailed, multi-part six-cylinder engine, a front end with multi-part tubular frame construction and an opening hood.

RVLS7291

Skill level 5



**1/16 SCALE '34 PHANTOM II CONTINENTAL**  
Live in the lap of luxury.

The 1934 Rolls-Royce® Phantom II Continental combined sophistication and luxury like no other car that came before it. Only 280 were ever produced, making them highly popular with today's car collectors. **Kit features** multi-part bodywork with finely structured surfaces, a multi-part six-cylinder engine with separate cables, a detailed interior with an authentic dashboard, textured seats and a separate rear bench; an opening hood, opening doors, front/rear leaf springs, turning wheels, countless chrome parts (including the "Spirit of Ecstasy" grille), realistic rims and authentic decals.

RVLS7459

Total parts: 179

Skill level 5

Length: 13.6 in (345 mm)



**1/16 SCALE 1951/1952 VW® BEETLE**  
Germany's most impressive export.

The VW Beetle is, without a doubt, one of the most-exported, most-popular vehicles to emerge from the 20th century. **Kit features** a detailed one-piece body; a multi-part flat-four engine with ignition coil, air filter and carburetor; a detailed undercarriage and separate exhaust assembly; an independent wheel suspension; a movable front axle; an opening hood and trunk; a detailed dashboard with flower vase; a two-spoke steering wheel and sun visor; movable seats; passenger compartment; assorted chrome parts and extensive decals with multiple license plate options.

RVLS7461

Total parts: 218

Skill level 5

Length: 10.2 in (259 mm)



**1/16 SCALE 1912 FORD® MODEL T**  
Efficiency to a "T"

Deliberately designed for simple operation and easy repair, the first Fords were efficient to a "T." To keep production costs down, Ford only made the Model T available in black from 1914 until 1925. By the time the final Model T's rolled off the assembly line in 1927, 15 million had been released. **Kit features** a large-sized chassis, multi-part bodywork, a three-part radiator, a textured multi-part roof, movable doors, textured seats, transverse leaf springs, steerable front wheels, rotating spoke wheels, six lamp sockets, extensive gilded chrome parts and authentic decals.

RVLS7462

Total parts: 126

Skill level 3

Length: 8.9 in (226 mm)

## HASEGAWA® PHOTO CONTEST

Show off your model building skills — and win a \$50 merchandise certificate!

- Upload pictures of your favorite Hasegawa model between October 1 and November 30, 2011 for a chance to win
- Model can be any subject, any scale — only one entry per person (must be U.S. resident)
- Public voting will take place from December 1-15, so get your friends and family involved!
- Judges will award a winner January 6, 2012
- Visit the Hasegawa USA Facebook page starting October 1 for all the details



### 1/72 F-4S PHANTOM II "LOW VISIBILITY CAG"

The U.S. Navy's last carrier-launched Phantom.

The final F-4S Phantom II ever launched from a U.S. Navy aircraft carrier belonged to the VF-151 "Vigilantes" fighter squadron. This historic launch took place aboard the U.S.S. Midway, on March 25, 1986. The squadron soon replaced their aging fleet of Phantom IIs with the cutting-edge F/A-18 Hornet, resulting in the end of an era which few aircraft have ever surpassed. This limited edition **kit features** one marking option: 1. U.S. Navy VF-151 "Vigilantes" CAG, Code: NF200, 1986.

01956 HSGS0156 (Limited Edition) Total parts: 162 Skill level 3



### 1/72 SCALE RF-101C VOODOO "OPERATION SUN-RUN" KIT COMBO

History's supersonic record-setter.

During 1957's Operation Sun-Run, Capt. Robert Sweet flew from L.A. to New York and back in only 6 hours and 46 minutes. Lt. Gustav B. Klatt also set his own record during the L.A. to New York flight, clocking in at 3 hours and 7 minutes. This limited edition **kit combo includes two kits and features** four marking options, representing U.S.A.F. 363TRW "Operation Sun-Run," November 27, 1957: 1. Lt. Gustav B. Klatt "Sun-Run 3"; 2. Capt. R.W. Schrecengost "Sun-Run 4"; 3. Capt. Robert M. Sweet "Sun-Run 1" and 4. Capt. Robert J. Kilpatrick "Sun-Run 2."

01953 HSGS1953 (Limited Edition) Total parts per kit: 48 Skill level 3



### 1/72 SCALE HEINKEL HE 111P/H "KG55"

Battle Wing 55's favored bomber.

Sporting a glazed, bullet-shaped "greenhouse" nose, the Heinkel He 111 rightfully earned a place among the Luftwaffe's most-recognized bombers. Kampfgeschwader 55 (Battle Wing 55) flew the Heinkel 111 from its 1935 introduction until WWII's end in 1945. This limited edition **kit features** three marking options: 1. Type P-2: Luftwaffe 3./KG55, Code: G1 + JL or 10./KG55, Code: G1 + JU; 2. Type H-2: Luftwaffe 1./KG55, Code: G1 + BH, 1940 and 3. Type P-2: Luftwaffe 2./KG27, Code: 1G + EK, 1939.

01954 HSGS1954 (Limited Edition) Total parts: 115 Skill level 3



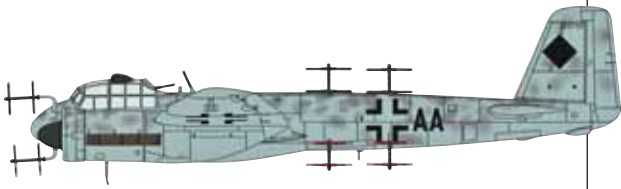

## 1/72 SCALE JUNKERS JU 88G-6 "SCHÖNERT"

The Luftwaffe's notorious night-fighting ace.

Rudolf Schönert was one of the Luftwaffe's most distinguished WWII flying aces. Scoring 65 "kills" in his career, Schönert was the seventh highest-scoring Luftwaffe night fighter ace during the war. For his remarkable combat service, Schönert was honored with the Knight's Cross of the Iron Cross with Oak Leaves in 1944. This limited edition **kit features** new SN-2 radar parts, new photo-etched parts and one decal marking option: 1. Luftwaffe NJG5 Kommodore Major Rudolf Schönert, Code: C9 + AA, April 1945.

01955 HSGS1955 (Limited Edition) Total parts: 161 Skill level 3



## 1/48 SCALE F/A-18B/D HORNET "BLUE ANGELS"

The Blue Angels' signature fighter.

The Blue Angels replaced their fleet of A-4 Skyhawks with the F/A-18 Hornet in 1986, and it's been a signature fighter for their routines ever since. In September 2011, the Blue Angels started using a 50/50 blend of conventional jet fuel and biofuel, which is far more environmentally friendly than earlier fuel mixtures. This limited edition **kit features** new vertical tail wing parts and two marking options: 1. F/A-18B: U.S. Navy aerobatic team "Blue Angels," Code: 7, 2011 and 2. F/A-18D: U.S. Navy aerobatic team "Blue Angels," Code: 7.

09956 HSGS9956 (Limited Edition) Total parts: 226 Skill level 3



## 1/48 SCALE F-15J EAGLE

### "MSIP CONFIGURATION II AIRCRAFT"

Factory-equipped with MSIP modifications.

Initiated in 1983, the F-15 Multistage Improvement Program (MSIP) ensured that the aircraft would receive the latest mods at regular intervals. F-15Js, which are produced in Japan under license, started receiving upgrades in 1987. The most significant changes included an upgraded central computer, more powerful engines and a J/APQ-1 countermeasure set. This limited edition **kit features** new resin and metal inlet conversion parts, plus two marking options: 1. J.A.S.D.F. A.D.T.W. "MSIP Configuration II," Code: 942 and 2. J.A.S.D.F. A.D.T.W. "MSIP Configuration I," Code: 929.

09957 HSGS9957 (Limited Edition) Total parts: 170 Skill level 3

# Plastic Models

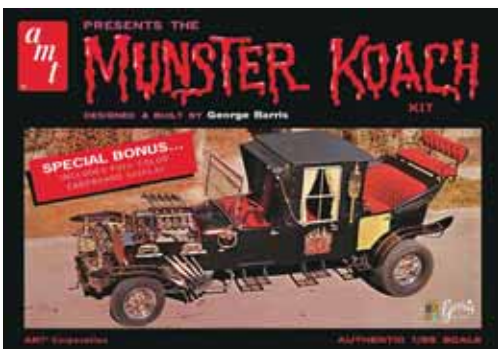

## AMT® 1/25 Scale The Munsters® Munster Koach

Ride along with the famous monster family.

Although The Munsters first aired on CBS in 1964 and lasted for only two seasons, the show continues to draw new fans nearly fifty years after it first premiered. Only 70 episodes of the series were produced, but the show's enduring popularity has spawned five movies and a less-successful revamp in the late 1980s. **Kit features** black, clear and chrome construction with colorful decals, as well as a full-color fold-out display base with backdrop. Combine the backdrop with the AMT 1/25 Scale Drag-u-La (sold separately) for an appropriately ghoulish display!

AMT647 AMTS0647 Skill level 2

## AMT® 1/25 Scale The Munsters® Drag-U-La

*Grandpa Munster's macabre mobile.*

In "Hot Rod Herman," Grandpa Munster (Al Lewis) builds the Drag-U-La to win back the Monster Koach after Herman loses it in a race. In reality, it was Tom Daniel and George Barris who created Grandpa Munster's macabre mobile! **Kit features** a coffin-shaped body, "organ pipe" exhaust pipes, a bubble canopy, a bonus "Surf Slab" surf board, a fold-together display base with backdrop, original box art and colorful decals. Combine the bases from this kit and the Munster Koach to create an eye-popping display.

AMT657 AMTS0657

Skill level 2



## AMT® 1/25 Scale NASCAR® Jimmie Johnson #48

*2010's pace-setting superstar.*

Founded by Bill France, Sr. in 1947, the National Association for Stock Car Auto Racing is the largest sanctioning body for stock car racing in the U.S. NASCAR events are among the most-watched pro sports events on television, with races broadcast internationally in 150 countries. **Kit features** easy Snap-It™ construction, all-new tooling, an updated rear spoiler and body extensions, an authentic interior and chassis, detailed windows and tires, rolling wheels, painted body graphics and a choice of stickers or water-release decals. No paint or glue required.

AMT707 AMTS0707

Skill level 1



## Airfix® 1/72 Scale Vickers Valiant B.Mk.1

*The RAF's fearless four-jet bomber.*

The Vickers Valiant was the first of the RAF's V-bombers, which were used for strategic nuclear strikes throughout the 1950s and 1960s. The "V-bomber" moniker was a result of all the squadron's aircraft (including the Avro Vulcan and the Handley Page Victor) beginning with the letter "V". **Kit features** engraved panel lines, a five-seat flight deck, an optional-position boarding hatch, bomb bay doors, a bomb bay with multiple bomb options, optional-position landing gear, weighted tires, separate ailerons and elevators, drop tanks and decals for four Royal Air Force aircraft.

11001 ARXS1101 Total parts: 142

Length: 18 in (456 mm)

Wingspan: 19.2 in (488 mm)



## MPC® Road Runner® & the Beep Beep "T"

*Lovably looney, even at breakneck speeds.*

The Model "T" quickly earned its place among the twentieth century's most significant inventions. Road Runner cartoons represent twentieth-century animation at its looniest, and they're still going strong over 60 years after their first silver screen appearance. **Kit features** easy Snap-It™ construction, molded plastic parts painted in orange and black, chrome-plated parts, a painted vinyl Road Runner figure and colorful stickers. No paint or glue required.

MPC718 MPCS0718

Skill level 1



## MPC® Wile E. Coyote® & the Wile E. Willys

*Still wily after 60+ years.*

The Willys Jeep® emerged during WWII, and soon it was regarded as the world's most iconic light utility vehicle. Wile E. Coyote became a pop culture icon after debuting in the 1949 short, "Fast and Furry-ous." This first appearance set the stage for 47 more cartoons, which continue to make generations of kids (and adults) laugh to this day. **Kit features** easy Snap-It™ construction, molded plastic parts painted in green and black, chrome-plated parts, a painted vinyl Wile E. Coyote figure and colorful stickers. No paint or glue required.

MPC719 MPCS0719

Skill level 1

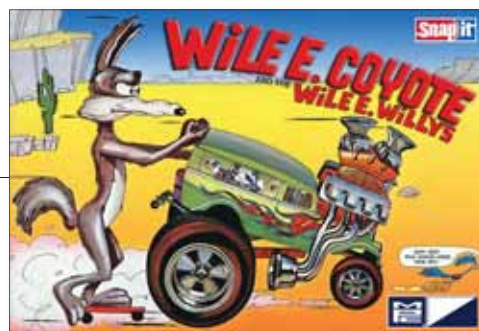

# ESTES® SKY TWISTER™ RTF LAUNCH SET

A fast-building cyclone of thrills.

- Rocket-launched helicopter nose cone features two-way recovery.
- E2X skill level: contains parts that are painted and easy to assemble, including plastic fins/fin units and nose cones. Just glue the parts as instructed, apply the self-stick decals and attach the recovery system. No paint or special tools needed.
- Includes a 12" (30.5 cm) recovery parachute, launch pad and launch controller.
- Requires engines, recovery wadding, igniters and 4 "AA" batteries
- Height: 19.5" (49.5 cm). Max. altitude of 650 ft (198 meters) with recommended C6-5 engine.



1438  
ESTT1438  
Sky Twister™ RTF Launch Set



## Long story short...

A helicopter nose cone makes the Sky Twister hover high above the clouds. You've never seen anything like it before!

# SCX® 1/32 SCALE MOTO GP C2 ASSEN SET

Authentic motocross action.

- Digital technology lets you switch lanes to overtake your opponent.
- 16'7" (5 m) track layout includes two 7" (175 mm) straights, six 13.8" (350 mm) straights, ten standard curves and one 13.8" (350 mm) terminal track.
- Set features two Moto GP racers: Ducati® "Rossi" and Yamaha® "Lorenzo."
- Other highlights include two controllers, two bridge supports, eight barriers and one electronic transformer.

A10055X500  
SCXW5155  
1/32 Scale Moto GP C2 Assen Set



## Long story short...

Moto GP fans will find this latest SCX set is as true to "the real thing" as possible in 1/32 scale.



# ATLAS® TRAINMAN® MIXED FREIGHT TRAIN SETS – HO SCALE

The Atlas Trainman tradition of quality continues.

- Locomotives feature a five-pole skewed armature motor with dual flywheels, separately applied hand rails and end railings, diecast underframes and AccuMate® couplers. GP38-2 models also include directional lighting.
- 4' x 3' (122 cm x 91 cm) oval True-Track® layout includes 12 curved pieces, 1 railer and 1 terminal track. Pieces feature realistic roadbeds, accurately sized brown ties and staggered spike detail.
- Freight cars feature weighted underframes, AccuMate knuckle couplers and trucks with free-rolling metal wheels.
- Caboose come with clear window inserts and separately applied side railings.
- Sets also include a Power Pack, instruction sheet, warranty card and a "Blueprints for Ten True-Track Layouts" book.



- ATLU0043 0043 BNSF (GP38-2)
- ATLU0044 0044 Canadian National (GP38-2)
- ATLU0045 0045 CSX® (GP39-2)
- ATLU0051 0051 Ferrocarriles Nacionales de México (GP38-2)



**Long story short...**

*These top-quality Atlas Trainman sets are the perfect gift for the budding conductor in your family!*

# LIONEL® NEW YORK CENTRAL FLYER SET – O SCALE

Ready to charge down the mainline.

- 0-8-0 steam locomotive and tender features: diecast body and frame, maintenance-free motor, transformer-controlled forward/neutral/reverse operation, TrainSounds® sound system, operating headlight, puffing smoke unit, traction tires, upgraded drive rod assembly and wheels with silver metal rims.
- 40" x 60" (1016 mm x 1524 mm) FasTrack® layout includes 3 straight sections, 8 curved sections, 1 terminal section and 1 uncoupling section.
- Rolling stock includes a boxcar with opening doors, a helicopter launch car with operating helicopter, a gondola with four "Pacemaker" canisters and a work caboose with interior illumination.
- All feature operating couplers. Rolling stock (except the caboose) includes diecast sprung trucks.
- Set also features a CW-80 transformer, smoke fluid and engineer/fireman figures.

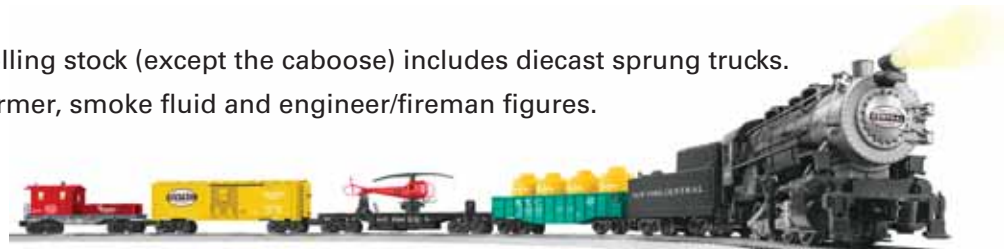

6-30156  
LNLU0156 New York Central Flyer Set – O Scale



**Long story short...**

*The Northeast's most celebrated railroad returns, as a spectacular, ready-to-run set from Lionel!*

# BACHMANN® SANTA SPECIAL SET – HO SCALE

Fully stocked with presents, for a very merry Christmas.

- The USRA 0-6-0 steam locomotive features tender and an operating headlight.
- Rolling stock consists of a gondola with presents, a reindeer transport stock car, a hot chocolate tank car and a North Pole & Southern bobber caboose. All feature body-mounted E-Z Mate® couplers.
- Complete, 47" x 38" (1194 mm x 965 mm) oval E-ZTrack® layout comes with 12 curved pieces, 1 straight piece and 1 plug-in terminal rerailer.
- Set also includes a speed controller, a power pack and an illustrated instruction manual.



00707  
BACU0707 Santa Special Set – HO Scale

**BACHMANN®**



## Long story short...

*The Santa Special is chock-full of Christmas cheer and holiday spirit. Even Scrooges will be satisfied!*

# BACHMANN® DURANGO & SILVERTON SET – HO SCALE

Still chugging, 130 years later.

- Realistic 2-8-0 steam locomotive comes with tender and an operating headlight.
- Rolling stock consists of an open excursion car, an old-fashioned combine and an old-fashioned coach.
- 47" x 38" (1194 mm x 965 mm) oval E-ZTrack® layout features 12 curved pieces, 1 straight piece and 1 curved plug-in terminal rerailer.
- Also includes a power pack, speed controller and an illustrated instruction manual.



00710  
BACU0710 Durango & Silverton Set – HO Scale

**BACHMANN®**



## Long story short...

*Bachmann has recreated one of history's most celebrated railroads, in an HO-scale set that's sure to satisfy.*

# BACHMANN® CIVIL WAR 150<sup>TH</sup> ANNIVERSARY TRAIN SETS – HO SCALE

Bridging the gap within a divided nation.



- 4-4-0 American locomotive comes with an operating headlight and tender.
- Both feature an historically accurate water car, boxcar, gondola, flat car and combine or bobber caboose.
- 56" x 38" (1422 mm x 965 mm) oval E-ZTrack® layout includes 12 curved pieces, 3 straight pieces and 1 plug-in terminal rerailer.
- Also included are 100 military figures, 3 cannons and 4 horses.
- Both sets also feature a power pack, speed controller and instructions.



BACU0708  
00708 Union



BACU0709  
00709 Confederate

## BACHMANN®

BACU0708  
00708 Union



BACU0709  
00709 Confederate



### Long story short...

*Our nation's most tumultuous time is recreated with these superbly detailed Civil War train sets, 150 years after the first shots were fired at Fort Sumter.*

## Bachmann® DCC-Equipped EMD GP7 Locomotives – HO Scale

*Seven dynamite HO scale diesels.*

- DCC-equipped for speed, direction and lighting.
- All feature diecast chassis, all-wheel drive, a can motor and E-Z Mate® Mark II couplers.

See GPDealer for a complete list of EMD GP7 locomotives.



**BACU1787**  
62408 Union Pacific® #114



**BACU1788**  
62409 Baltimore & Ohio #6411

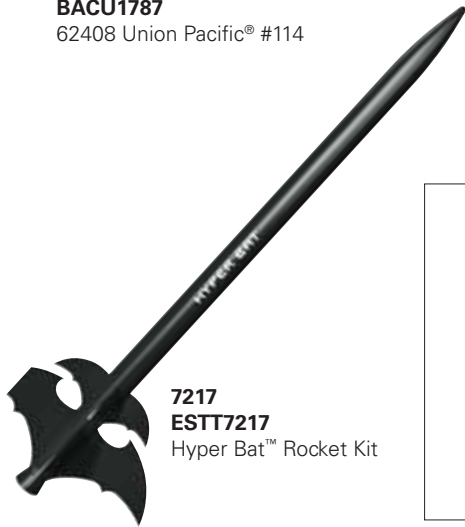

**7217  
ESTT7217**  
Hyper Bat™ Rocket Kit

## Estes® Hyper Bat™ Rocket Kit

*Soar off the launch pad with cool "bat" wings!*

- Features a plastic nose cone, laser-cut fins, a 12-inch (30.5) recovery parachute and waterslide decals.
- Requires a standard engine, a launch system, recovery wadding, igniters and igniter plugs.
- Skill level 2. Max. Altitude: 2125 ft. (648 m). Height: 21.9 in (55.6 cm).



**26064  
FDVX2664**  
Visible Human Head Anatomy Kit

## 4D Vision™ Visible Human Head Anatomy Kit

*The quick, easy way to get ahead.*

- Medical-quality model features finely detailed sculpturing with hand-painted parts.
- Includes an illustrated guide book. 4 parts. No glue or paint required.
- Approx. height: 4.5 in (114 mm).



**36700  
SLYH6700**  
Don't Upset Me Game

## Ideal Toys® Don't Upset Me Game

*The game where turnabout is fair play.*

- A must-have for any child of the 1980s.
- Round and round the shiny ball goes, where it stops nobody knows!
- 2-4 players. Ages 5 and up.

# ESTES® ROCKETS: A SCOUT'S



Enjoyed for generations, model rocketry is an engaging activity that continues to delight scouts of all skill levels. Science and space-themed projects have always been part of the scouting experience – with model rocketry among the most popular pastimes. Are you ready to get started? Great! Ask your Scout Pack leader about which Merit Badges you can earn, and then contact your local hobby shop to help you decide which Estes rockets best suit your need!

## Cub Scouts® & Brownie Scouts®



**Shuttle Xpress™**

Easy to Assemble **E2X**

ESTT2183

**Sky Writer®**

Easy to Assemble **E2X**

ESTT1260



**Firehawk™**

Easy to Assemble **E2X**

ESTT0804

E2X® (Easy to Assemble) rockets are a fun way for younger Scouts to figure out the fundamentals of model rocketry. Choices shown here, such as the Firehawk, Sky Writer and Shuttle Xpress, assemble in less than an hour. No painting is required. Most parts are pre-decorated, and many also include self-adhesive decals for first-class finishing touches!

## Webelos® & Junior Girl Scouts®

**Alpha III™**

Easy to Assemble **E2X**

ESTT1427



**Cosmic Cobra™**

Easy to Assemble **E2X**

ESTT1262

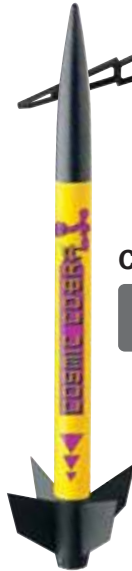

**Gold Strike™ / Bonus Silver Streak™**

Easy to Assemble **E2X**

ESTT2430



Although they're still easy to assemble E2X models, these rockets are better suited for more experienced Scouts, due to faster performance and detailed designs.

## Boy Scouts® & Girl Scouts®

**Der Red Max™**

Skill Level **1**

ESTT0651



**Quark™ Mini**

Skill Level **1**

ESTT0802



**Guardian™**

Skill Level **2**

ESTT2179



Older Scouts who have mastered E2X rockets will want to step up to the next skill level. Although Skill Level 1 and Skill Level 2 rockets require further assembly, painting and decorating, Scouts will quickly discover that the challenge is worth the reward!

# FAVORITE PASTIME!

## Recommended Bulk Packs

Cub Scouts® & Brownie Scouts®



UP Aerospace SpaceLoft Bulk Pack (12)

Easy to Assemble **E2X**

ESTT1793

Cub Scouts® & Brownie Scouts®

Webelos® & Junior Girl Scouts®



Generic Ed. Pack (12)

Easy to Assemble **E2X**

ESTT1764

Cub Scouts® & Brownie Scouts®

Webelos® & Junior Girl Scouts®



Alpha III Ed. Pack

Easy to Assemble **E2X**

ESTT1751

Boy Scouts® & Girl Scouts®



Wizard Ed. Pack

Skill Level **1**

ESTT1754

Boy Scouts® & Girl Scouts®



Viking Skill Ed. Pack

Skill Level **1**

ESTT1755

Boy Scouts® & Girl Scouts®



Alpha Ed. Pack

Skill Level **1**

ESTT1756



GIRL SCOUTS



BOY SCOUTS OF AMERICA



**ESTES**  
EDUCATOR.com  
launch learning fun

For more information, log onto [esteseducator.com](http://esteseducator.com) and click on the "Find Rockets for your Programs" button. There you'll find information about many different youth programs. Contact your local Scouting organization about getting Estes rockets in the hands of the Scouts in your area. Who knows? You or someone you know may be the next astronaut!



TURN HERE FOR RADIO CONTROL PRODUCTS

# GREAT



**NEWS<sup>®</sup>**

**T PLANES<sup>®</sup>**

**D I S T R I B U T O R S**