

Heli-Max®

Click part numbers for more information

AXE™ 100CP

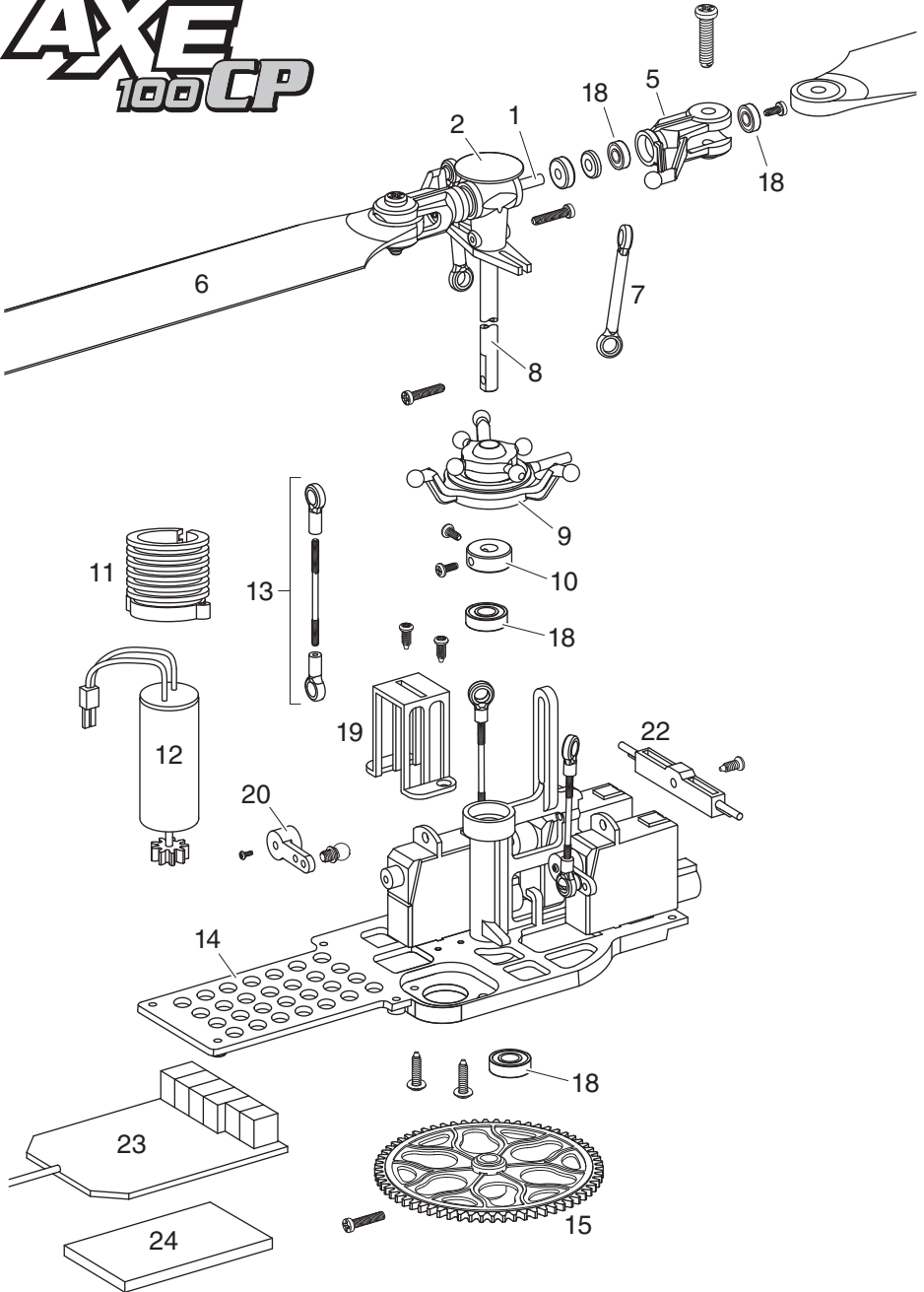

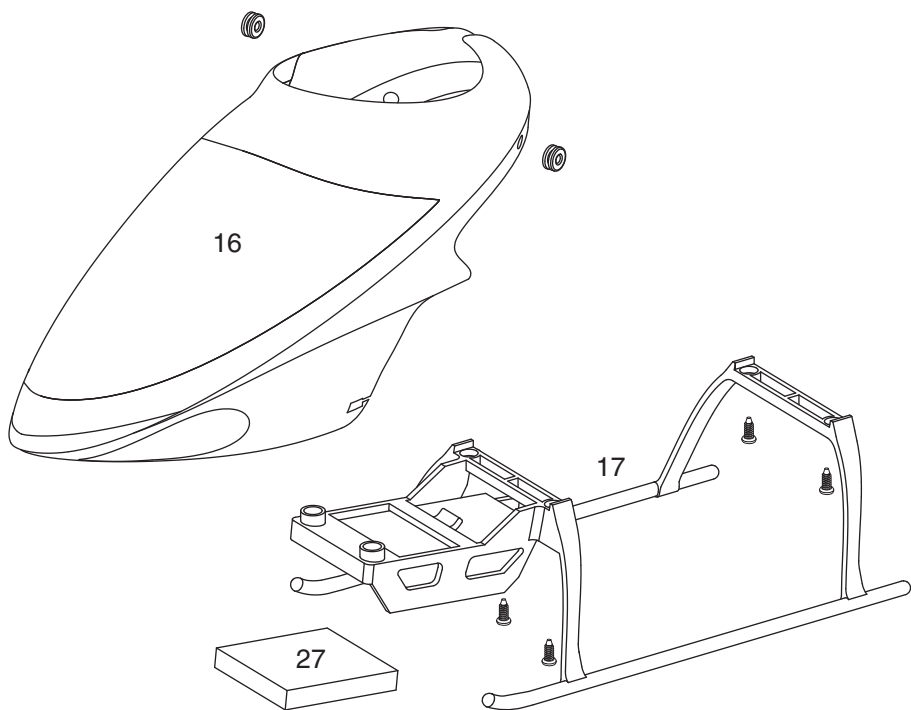
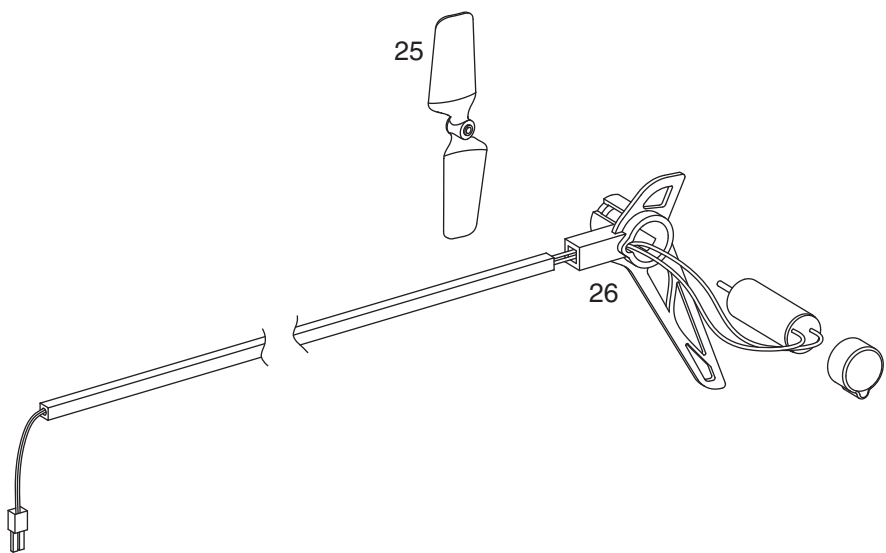

KEY NO.	NUMBER	PART
1	HMXE2100	Feathering Shaft
2	HMXE2101	Rotor Head
3	HMXE2102	Rotor Head Rubber Dampers
4	HMXE2103	Rotor Head Blade Grip Spacers
5	HMXE2104	Blade Grips
6	HMXE2105	Rotor Blades Axe 100 CP, Axe 100 FP, MD530
7	HMXE2106	Rotor Head Linkages
8	HMXE2107	Main Shaft
9	HMXE2108	Swashplate Assembly
10	HMXE2109	Main Shaft Collar Axe 100 CP, Axe 100 FP, MD530
11	HMXE2110	Motor Mount
12	HMXG8004	Main Motor with Pinion Gear
13	HMXE2111	Servo Linkages
14	HMXE2112	Main Frame
15	HMXE2113	Main Gear
16	HMXE2114	Canopy
17	HMXE2115	Landing Skids
18	HMXE2116	Bearing Set
19	HMXE2117	Elevator Servo Mount
20	HMXE2118	Servo Arms with Ball Links
21	HMXE2119	Screw Set
22	HMXE2120	Canopy Servo Mount
23	HMXM2036	T.A.G.S. Gyro and Control Board Axe 100 CP, FP, MD530
24	HMXE2121	Control Board Mounting Tape
25	HMXE2122	Tail Rotor Blade
26	HMXG8027	Tail Motor with Tail Boom Assembly
27	HMXP1008	1S 200mAh LiPo
28	HMXM2037	1.9g Digital Servo
29	HMXJ2025	610 SLT 2.4GHz 6-Channel 10 Model Transmitter
30	HMXE2123	Battery Plug Adaptor with JST Plug
31	HMXP2022	A/C Variable Rate Charger
	HMXE2124	Assembled Rotor Head with Blade Grips